

**CityScapes**<sup>®</sup>  
ARCHITECTURAL  
INNOVATIONS



# ENVISOR<sup>®</sup>

A PATENTED ROOFTOP SCREENING SYSTEM

---

INSTALLATION INSTRUCTIONS - POST MOUNTED SYSTEM



**(877) 727-3367**  
CITYSCAPESINC.COM  
BIDS@CITYSCAPESINC.COM

BUILD AMERICA, BUY AMERICA ACT (BABAA) CERTIFIED

# TABLE OF CONTENTS

---

- 4** | System Overview
- 4** | Getting Started
- 5** | Parts & Components List
- 8** | Post Mounted System Exploded View
- 9** | Post Mounted Install Steps
- 13** | Rail Splice Install Steps
- 18** | Top Trim Assembly – Lineal Band, 2-Step, & 3-Step
- 22** | Top Trim Assembly – Alamo & Cove
- 24** | Stacked System Install Steps
- 25** | Gap Brace Install Steps
- 30** | Annual Maintenance
- 31** | Replacement Part Ordering

# SYSTEM OVERVIEW

Envisor® components are designed to function as an Equipment Screening System. "Modular by Design" allows for a more user-friendly installation. This instruction manual is intended to communicate the "typical" Envisor® screen post mounted installation. As you will see in the following pages, **rooftop units (RTUs)** vary greatly in size, performance accessories, and power supply requirements. Each screen ships as a knockdown assembly, with **Job Specific Submittal Drawings, Parts Lists** and **Instructions**. Please review these pages carefully. We encourage you to call or e-mail your questions and thank you for your interest in Envisor® equipment screens.

## GETTING STARTED





If there are multiple RTUs, be sure to match the correct Envisor® screening components to the appropriate equipment. Component crates will be labeled with a **Sales Order Number**. All units have their own layout drawings included in the **Job Specific Submittal Packet** with the installation instructions. Review the area around the RTU for obstructions or supply lines that may interfere with the screening components during installation.

### RECOMMENDED TOOLS FOR ASSEMBLY:

- Framing Square
- Level
- Tape Measure
- Cordless Drill
- Miter Saw
- Reciprocating Saw (with metal cutting blades)
- 5/16" Drill Socket (nut driver)
- 3/8" Combination Wrench
- 7/16" Combination Wrench
- 3/8" Socket
- 7/16" Socket
- 1/8" Drill Bit
- 5/16" Drill Bit
- 17/32" Drill Bit
- Quick Clamps (optional)

# PARTS & COMPONENTS LIST

## MAIN SYSTEM PARTS:

	Top & Bottom Rail		1/4" - 20 x 3/4" Hex Head Bolts
	Sliding Panels		End Cap (Includes #12-14 x 1 1/4" Tek Screws)
	#12-14 x 1 1/2" TEK Screws		

## POST HARDWARE KIT:

	Post Angle Brackets		1/2"-13 x Hex Head Bolts (length varies on post size)
	1/2" Flat Washer		1/2" Lock Washer
	1/2" x 13 Hex Nut		

RAIL SPLICE KIT (STANDARD):



Splice (16" X Frame)



2" Hex Head Bolts  
(Standard)



1/4" Flat Washers



1/4" Lock Washer

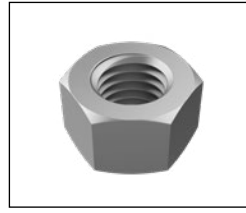

1/4"-20 Hex Nut

RAIL SPLICE KIT (QUICK RELEASE):



Splice (16" X Frame)



Quick Release Pins  
(Submittal Specific Part)

TOP TRIM PARTS:

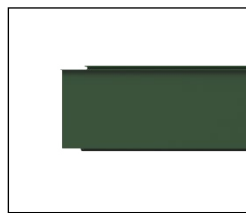

Left Top Trim



Right Top Trim



Straight Top Trim



Corner Piece Top Trim  
(For Alamo and Cove  
Trim Styles Only)

**Quick Tip:** Use an oil-based lubricant as needed to help assemble.

TOP TRIM PARTS CONTINUED:



Splice Key

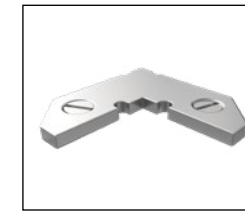

Corner Key

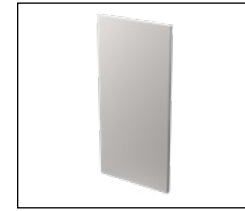

Splice Plate

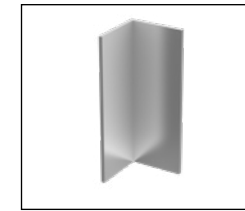

Corner Tab

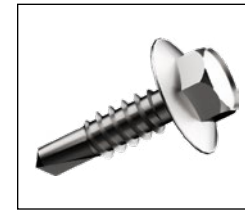

#10-16 x 3/4" TEK  
Screws

DISCONNECT STICKER, TOUCH UP PAINT & NAME PLATE:

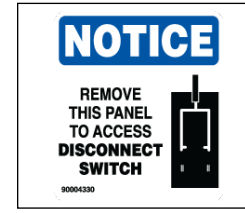

Disconnect Sticker



Touch Up Paint



Name Plate



Drive Pin Rivet 1/8" x  
1/8" Stainless Steel

# ENVISOR® EXPLODED VIEW

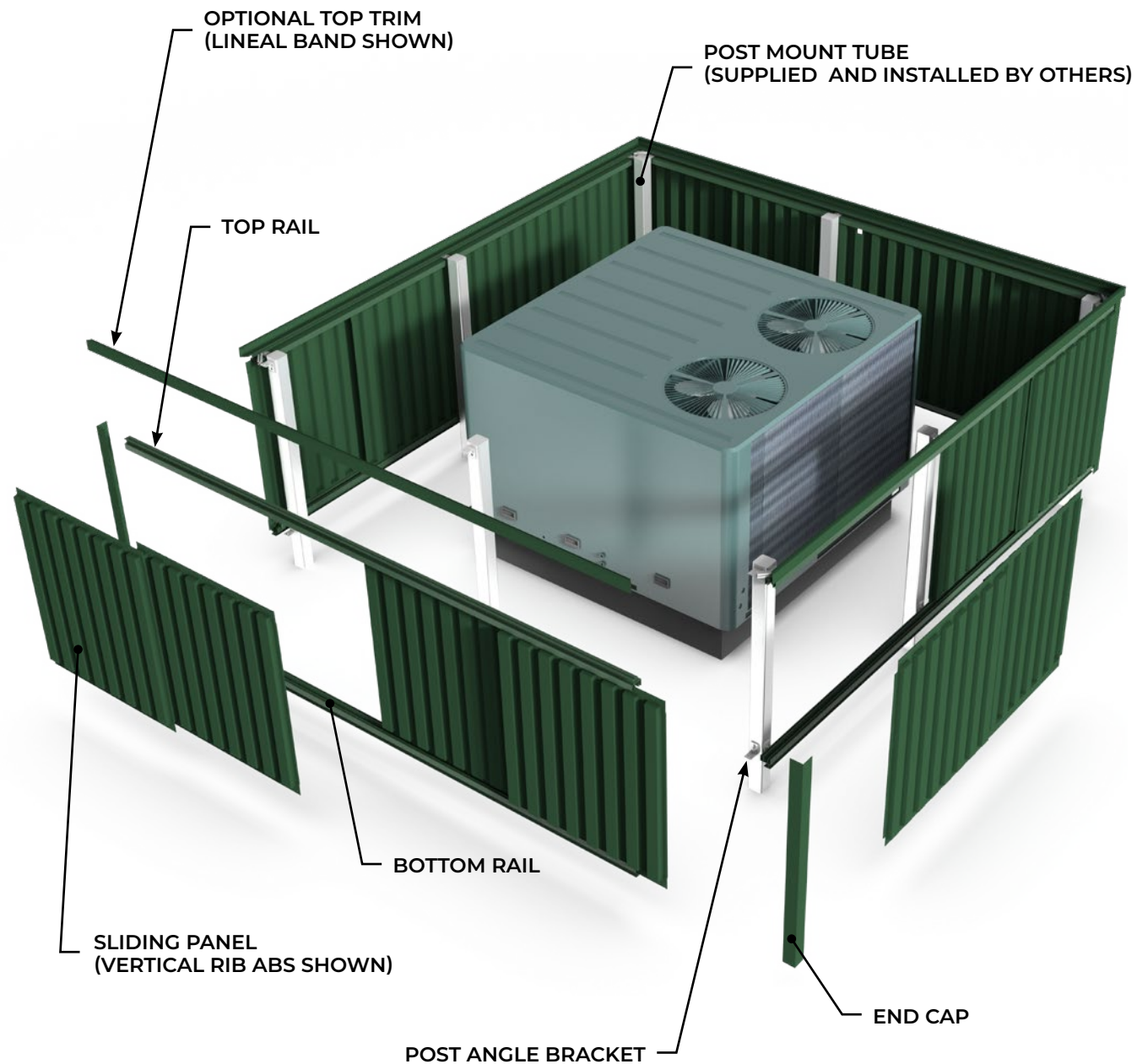

# POST MOUNTED INSTALL STEPS

**IMPORTANT: Posts are supplied and installed by others**

1. Measure and mark the posts:
  - 1.1. Choose a post to start. If posts have different heights, start with the shortest post.
  - 1.2. Using a **POST ANGLE BRACKET** as a guide, mark one bolt hole at the top and one at the bottom of the post, making sure the marks are centered. **Bolt hole placement and spacing MUST match the Job Specific Submittal Drawings to hold panels in place.**
  - 1.3. For corner posts, use leveled **POST ANGLE BRACKETS** as a guide and mark at alternating holes to allow proper hardware placement.
2. Repeat for all posts. Make sure that all top and bottom marks are level.

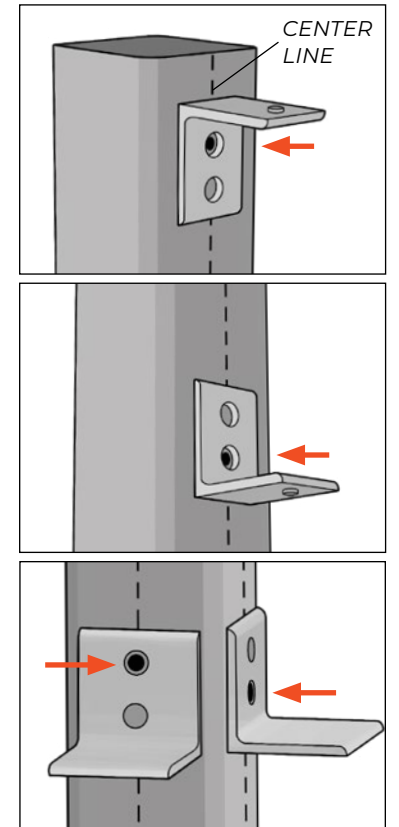

## EXAMPLE DRAWING

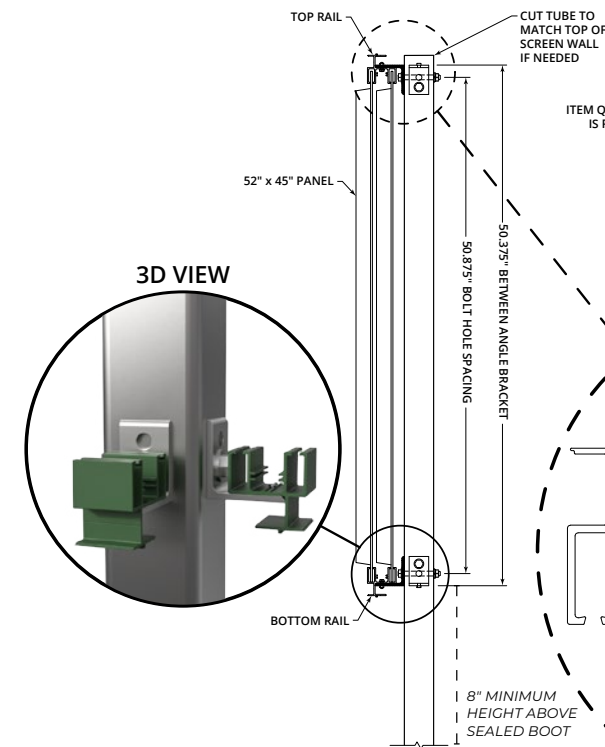

BILL OF MATERIAL			
ITEM	QTY	PART NO.	DESCRIPTION
A	2	12500099	BOLT HEX HD 1/2-13 X 4 S/S
B	8	12500046	1/2\"/>

3. Drill 17/32" through-holes at all marked points, checking for level. **For corner posts, make sure to drill at the correct alternate marked points on each face.**
4. Secure **POST ANGLE BRACKETS** with **HEX HEAD BOLTS** (size varies according to the **Job Specific Submittal Drawings**), **FLAT WASHERS**, **LOCK WASHERS** and **HEX NUTS**. **Do NOT fully tighten.**

4.1. Connect the **BOTTOM POST ANGLE BRACKETS** to the bottom post holes in an "L" shape with hardware through the lower bolt holes.

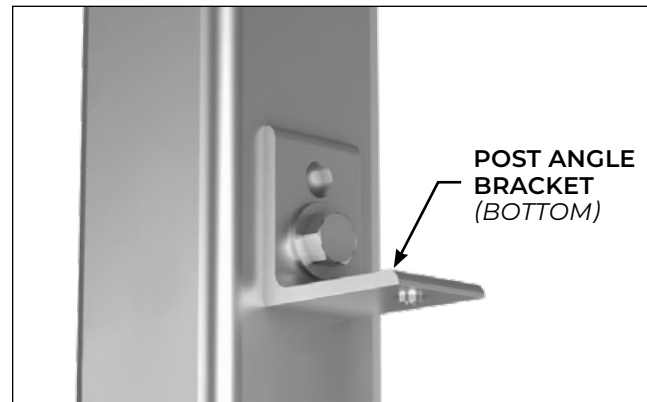

4.2. Connect the **TOP POST ANGLE BRACKETS** to the top post holes in an upside-down "L" shape with hardware through the upper bolt holes.

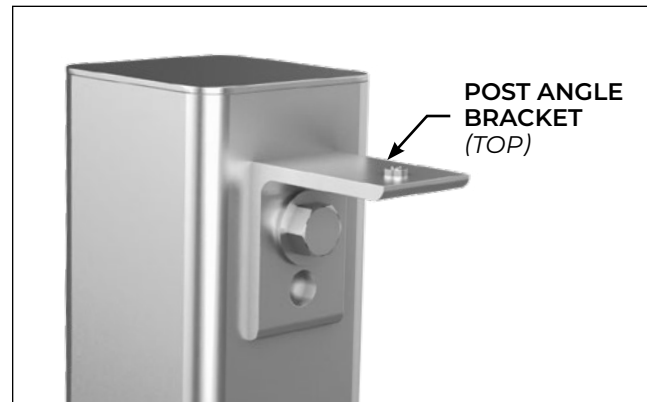

4.3. For corner posts, **connect all top and bottom brackets with hardware through alternating upper and lower bolt holes.**

4.4. Check that all **TOP and BOTTOM POST ANGLE BRACKETS** are level and aligned, then tighten all hardware.

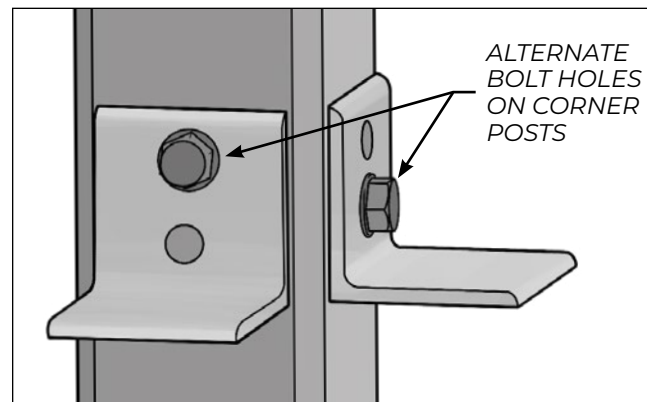

5. Place a **BOTTOM RAIL** on to the **BOTTOM POST ANGLE BRACKETS** and secure with **3/4" HEX HEAD BOLTS** through the PEM nuts.
  - 5.1. Repeat for all **BOTTOM RAILS**.
  - 5.2. If the distance between posts is longer than a single **BOTTOM RAIL**, splice two **BOTTOM RAILS** together with the **RAIL SPLICE KIT** provided (instructions on page 13).

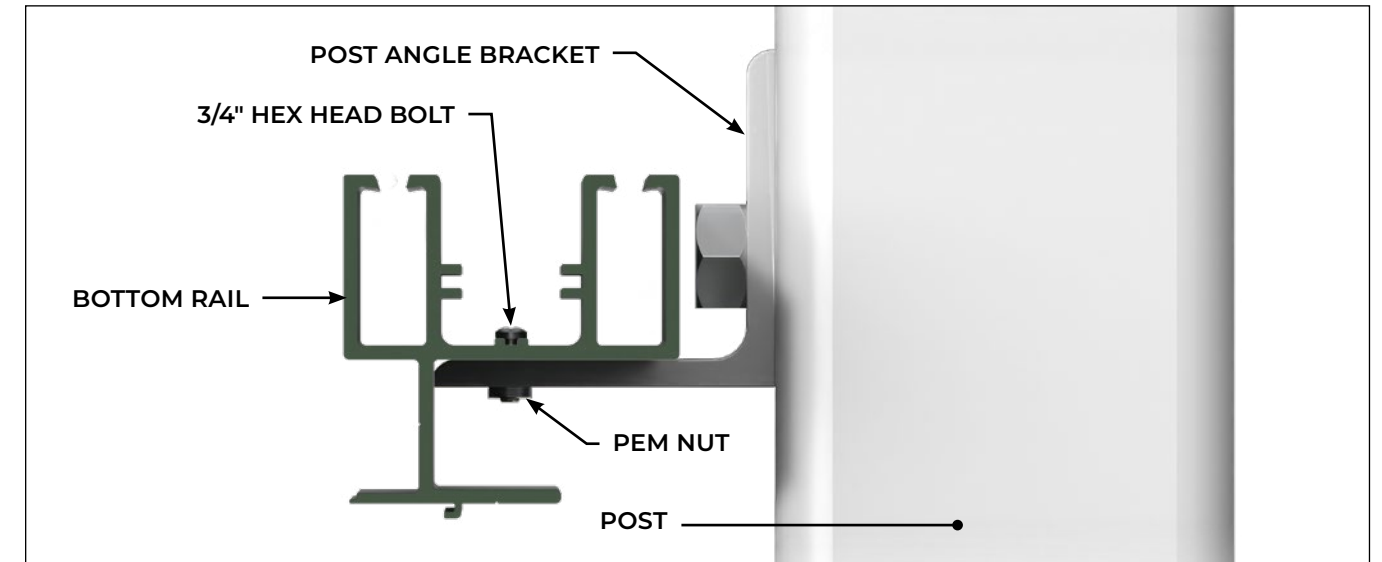

6. Lift a **TOP RAIL** up to the **TOP POST ANGLE BRACKETS** and secure with **3/4" HEX HEAD BOLTS** through the PEM nuts.
  - 6.1. Repeat for all **TOP RAILS**.
  - 6.2. If the distance between posts is longer than a single **TOP RAIL**, splice two **TOP RAILS** together with the **RAIL SPLICE KIT** provided (instructions on page 13).

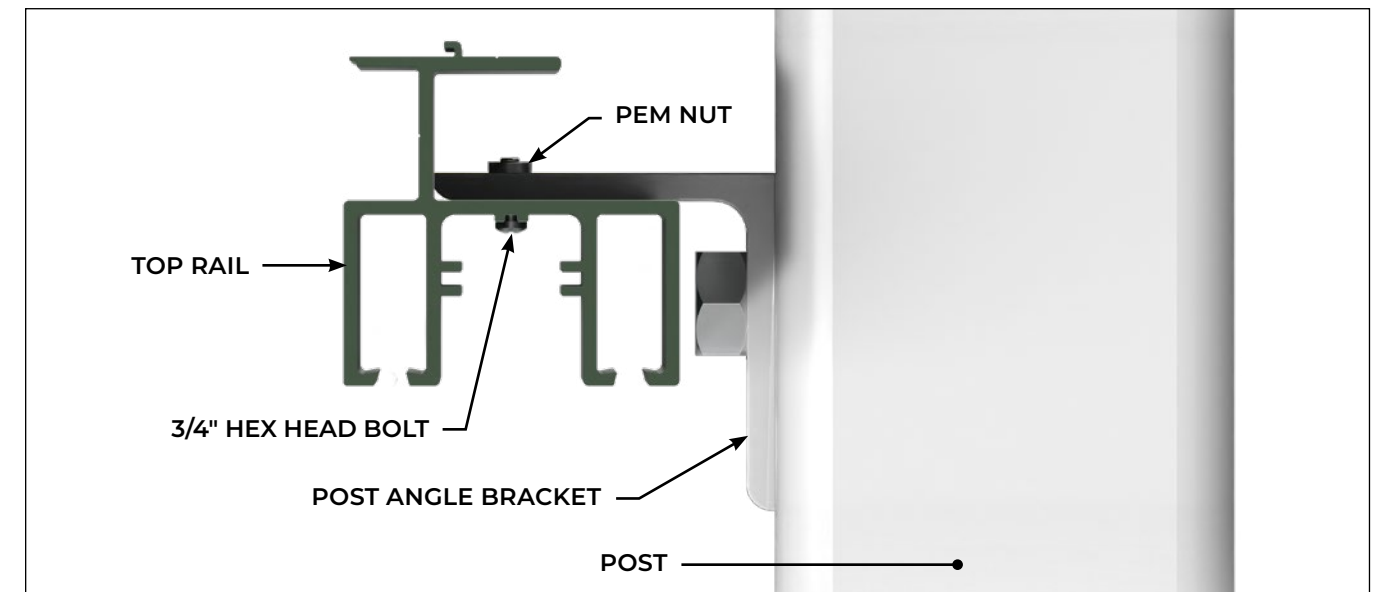



*If the Job Specific Submittal Packet includes a RAIL SPLICE KIT, go to the RAIL SPLICE INSTALL STEPS on page 13.*

*Otherwise, skip to page 17.*

# RAIL SPLICE INSTALL STEPS

## RAIL SPLICE KIT (STANDARD):



Splice (16" X Frame)



2" Hex Head Bolts  
(Standard)



1/4" Flat Washers



1/4" Lock Washer

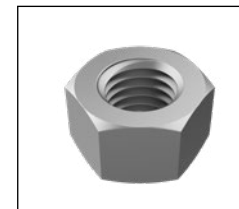

1/4"-20 Hex Nut

## RAIL SPLICE KIT (QUICK RELEASE):



Splice (16" X Frame)

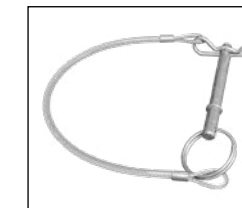

Quick Release Pins  
(Submittal Specific Part)

BILL OF MATERIAL			
ITEM	REQ	PART#	DESCRIPTION
1	1	80000156	1 1/8" X 1 1/8" FRAME EXTRUSION 16" LG.
2	4	12500028	BOLT HEX HD 1/4-20 X 2 SS
3	8	12500007	1/4"-20 FLAT WASHER SS
4	4	12500006	1/4"-20 HEX NUT SS
5	4	12500008	WASHER SPLIT LOCK 1/4 SS

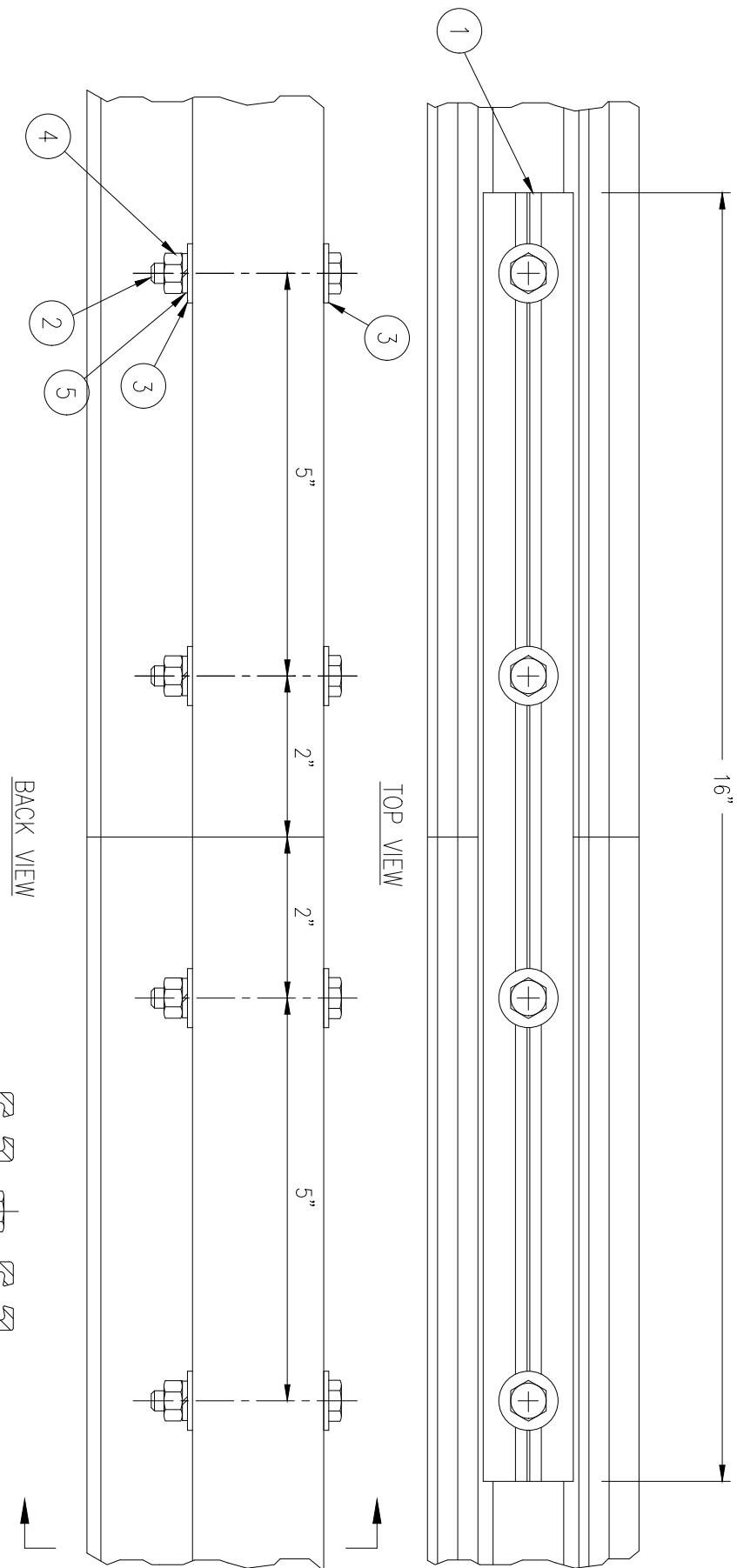

NOTE: MAXIMUM DISTANCE BETWEEN SPLICE IS 168"

1. Insert the **SPLICE (X FRAME)** completely into the end of one **RAIL**.

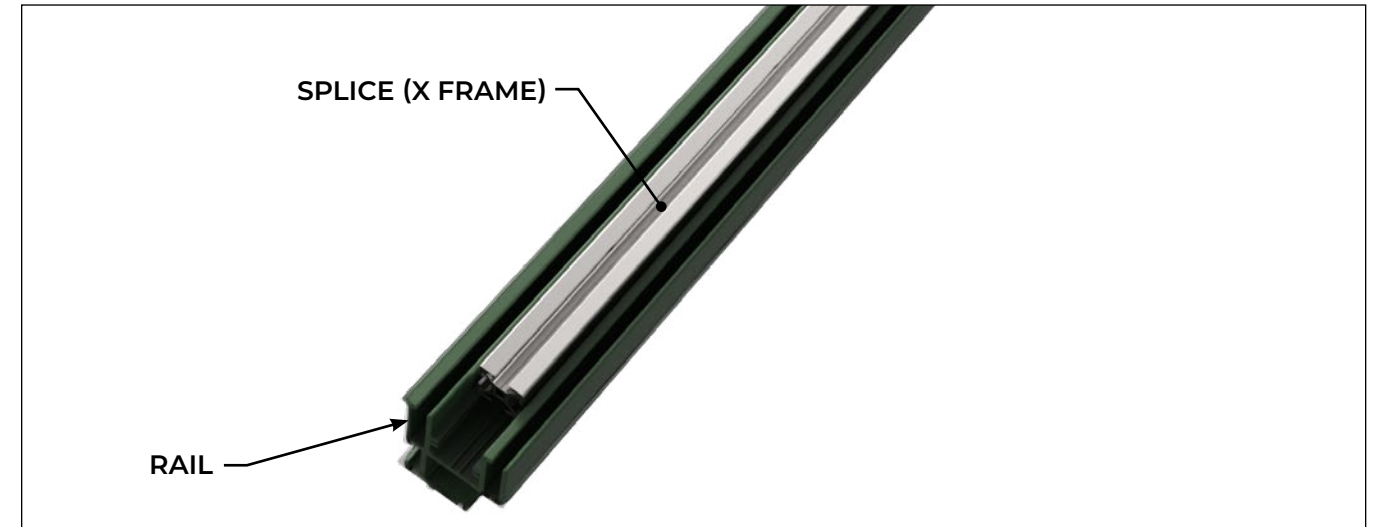

2. Line up the second rail and slide the **SPLICE (X FRAME)** so that it spans the joint between the two **RAILS**.

3. Using a 5/16" drill bit, drill 4 vertical holes through the **SPLICE (X FRAME)** and **RAILS**. Make sure there are 2 holes on each side of the **RAIL** joint.

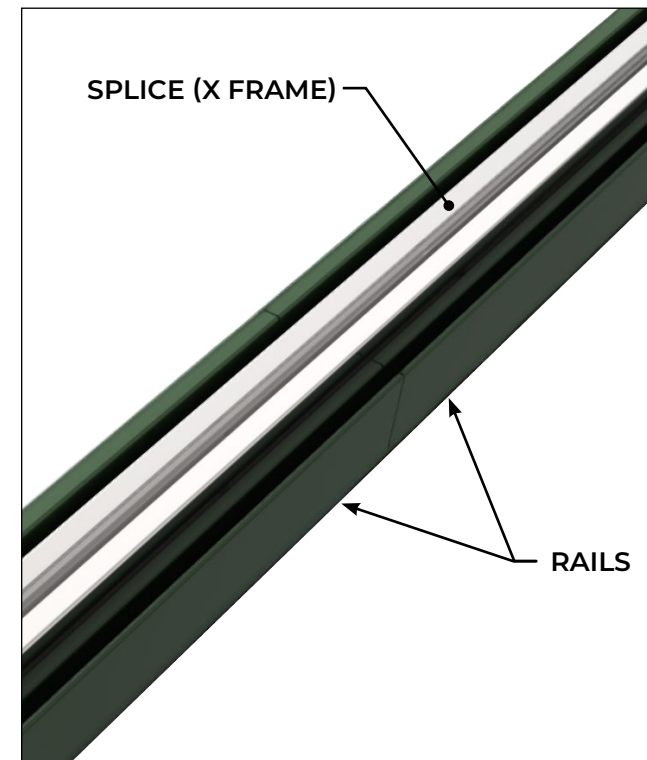

4. Secure the **SPLICE (X FRAME)** with a **2" HEX HEAD BOLT**, **FLAT WASHERS**, **LOCK WASHER** and **HEX NUT** in each through hole.

4.1. If **QUICK RELEASE PINS** are provided, insert them in place of the other fastening hardware mentioned above.

4.2. *Refer to the Job Specific Submittal Drawings for location to be used.*

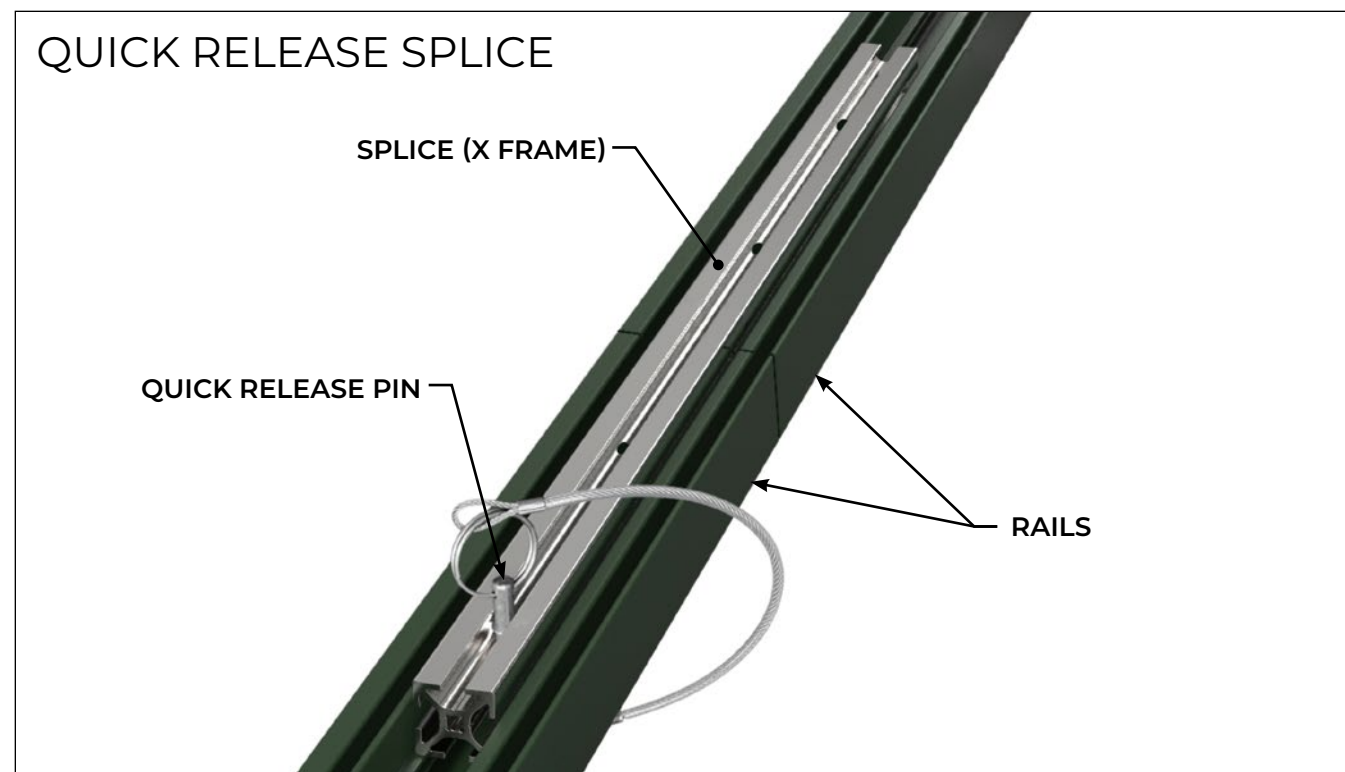
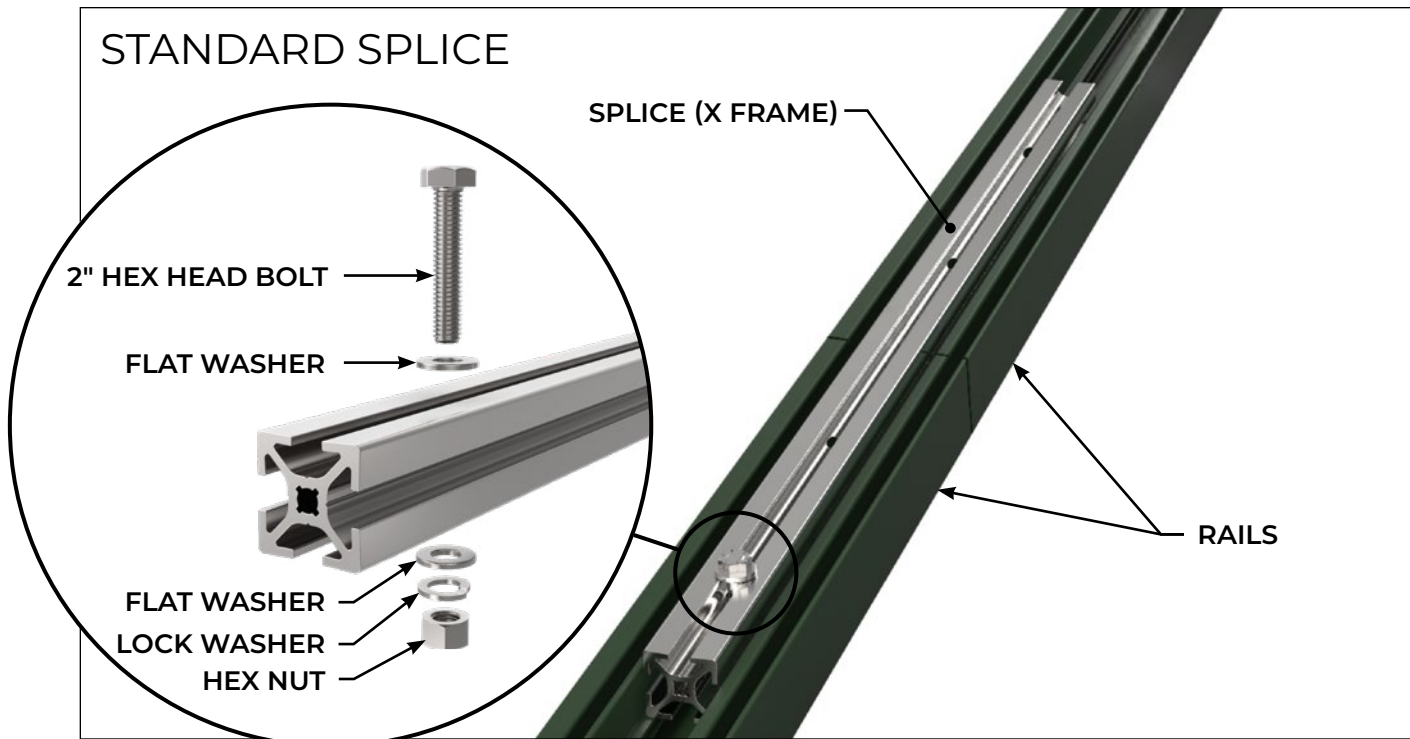

Before continuing, check the **Job Specific Submittal Packet** and **Packing List**. Follow the matching kit instructions below:

- **TOP TRIM ASSEMBLY – Lineal Band, 2-Step, & 3-Step**, go to page 18
- **TOP TRIM ASSEMBLY – Alamo & Cove**, go to page 22
- **STACKED SYSTEM INSTALL STEPS**, go to page 24
- **GAP BRACE INSTALL STEPS**, go to page 25

After completing the steps above (or if none apply), continue with the main **POST MOUNTED INSTALL STEPS** on page 27.

# TOP TRIM ASSEMBLY

## LINEAL BAND, 2-STEP, & 3-STEP

The **TOP TRIM** is fabricated from aluminum components and attaches to the **TOP RAIL** with **3/4" TEK screws**.



3" Lineal Band



2-Step



3-Step

1. Layout the **TOP TRIM** pieces on the ground to ensure you have the correct lengths for each side of the Envisor® screen.
2. While pieces are on the ground, join a mitered corner by connecting a **LEFT TOP TRIM** piece to a **RIGHT TOP TRIM** using the **CORNER TABS** and **CORNER KEYS**.
  - 2.1. Insert the **CORNER KEY** into the horizontal channel located on the back of the **TOP TRIM**.
  - 2.2. Secure the **CORNER KEY** to the right **TOP TRIM** piece using the flat head screws that are already set into the **CORNER KEY**.

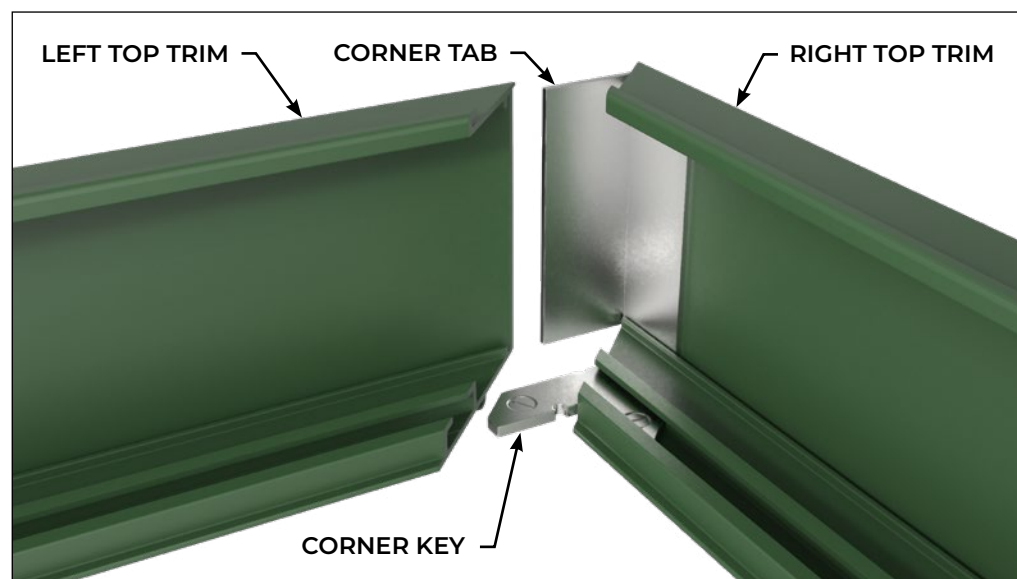

- 2.3. Install the **CORNER TAB** in the vertical channel of the **RIGHT TOP TRIM**, with the point of the angle at the edge of the piece.
- 2.4. Connect to the **LEFT TOP TRIM** and secure with flat head screw already in **CORNER KEY**.

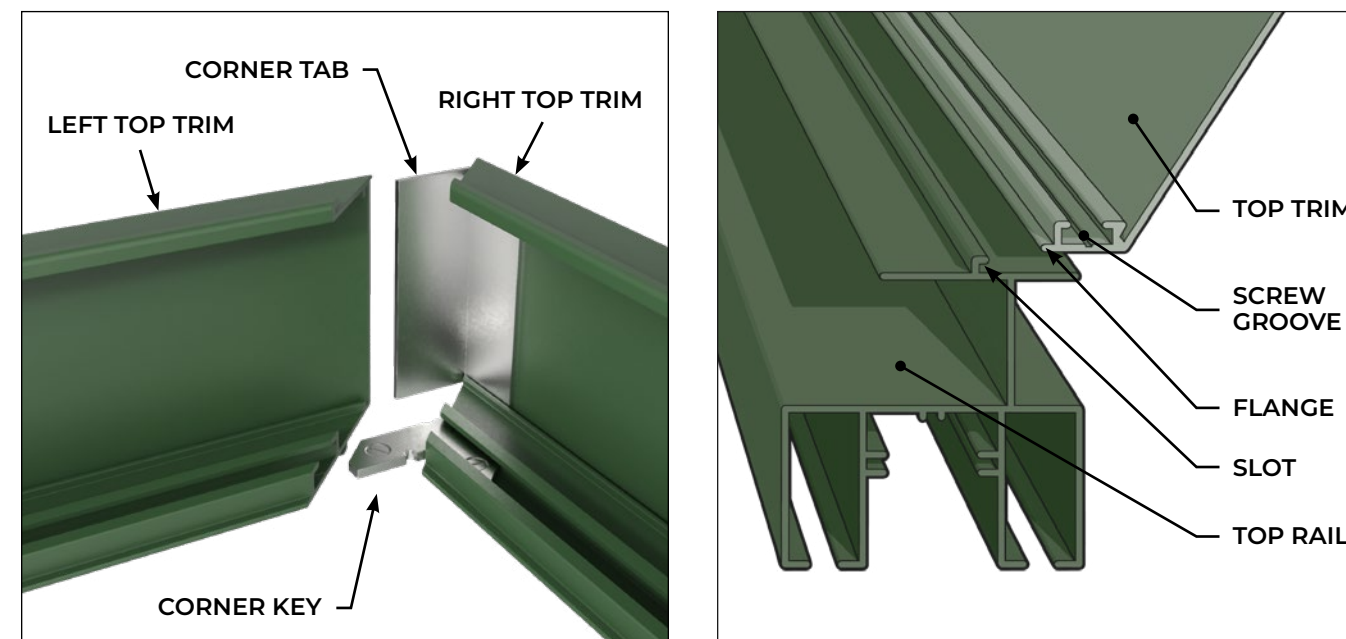

3. Lift the mitered assembled corner and insert the flange into the slot along the top of the **TOP RAILS**. Secure with several **3/4" TEK SCREWS** every 12" through the screw groove. *The screws will be visible from the outside.*
4. Measure the distance from this installed piece to the next corner.

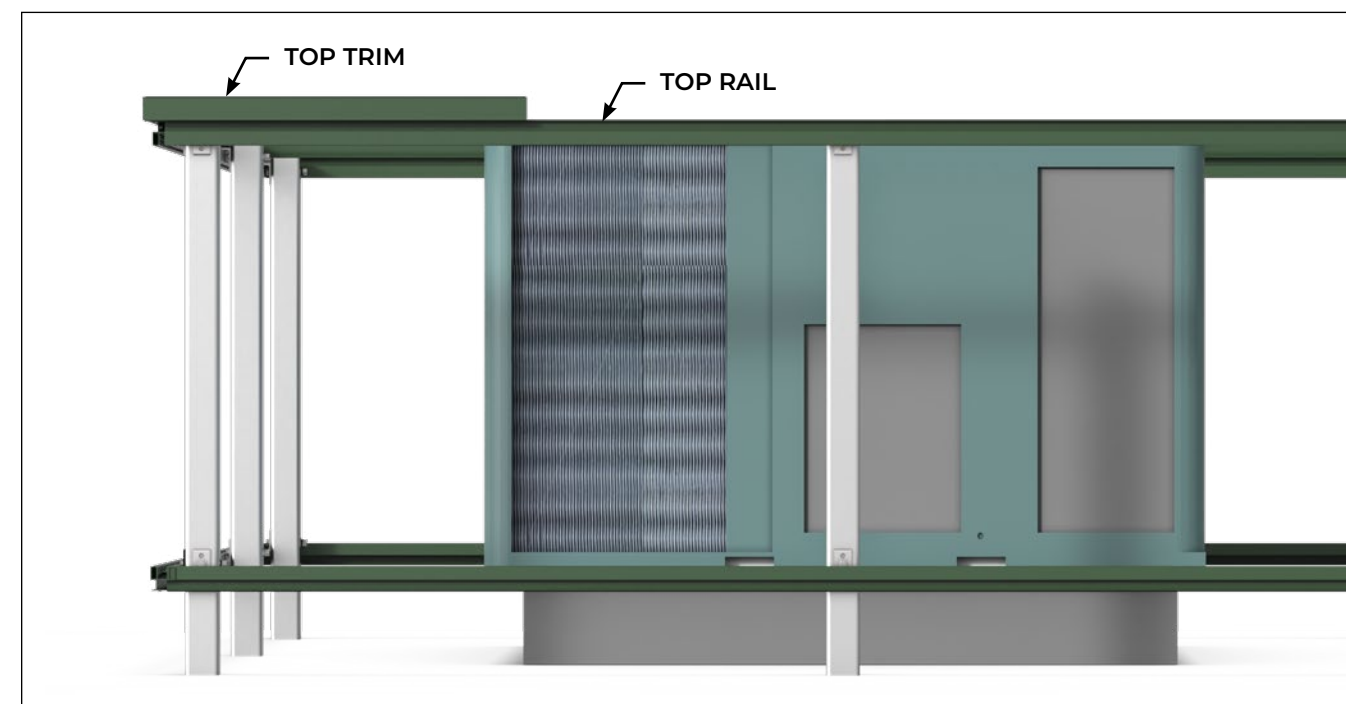

5. Cut a piece of **TOP TRIM** on the straight end to this measurement.

**⚠️ 5.1. Do not cut the mitered end. Cuts must be located at least 24" from the mitered corners.**

**5.2.** Save any trimmed (drop) pieces to use on other sides to fill gaps between **TOP TRIM** mitered pieces.

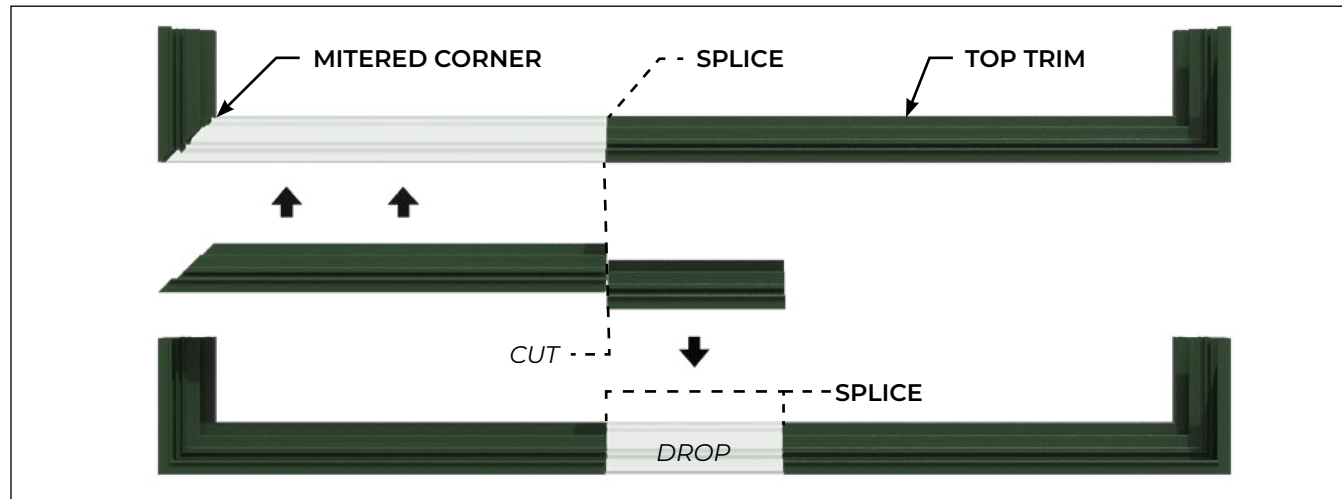

6. Use the **SPLICE KEYS** and **SPLICE PLATES** to connect these pieces.

**6.1.** Insert the **SPLICE KEY** into the horizontal channel located on the back of the **TOP TRIM**.

**6.2.** Secure the **SPLICE KEY** to each **TOP TRIM** piece with **3/4" TEK SCREWS**.

**6.3.** Insert the **SPLICE PLATE** into the vertical channels.

**6.4.** Make sure the **SPLICE KEY** and **SPLICE PLATE** overhang the cut end of the **TOP TRIM**.

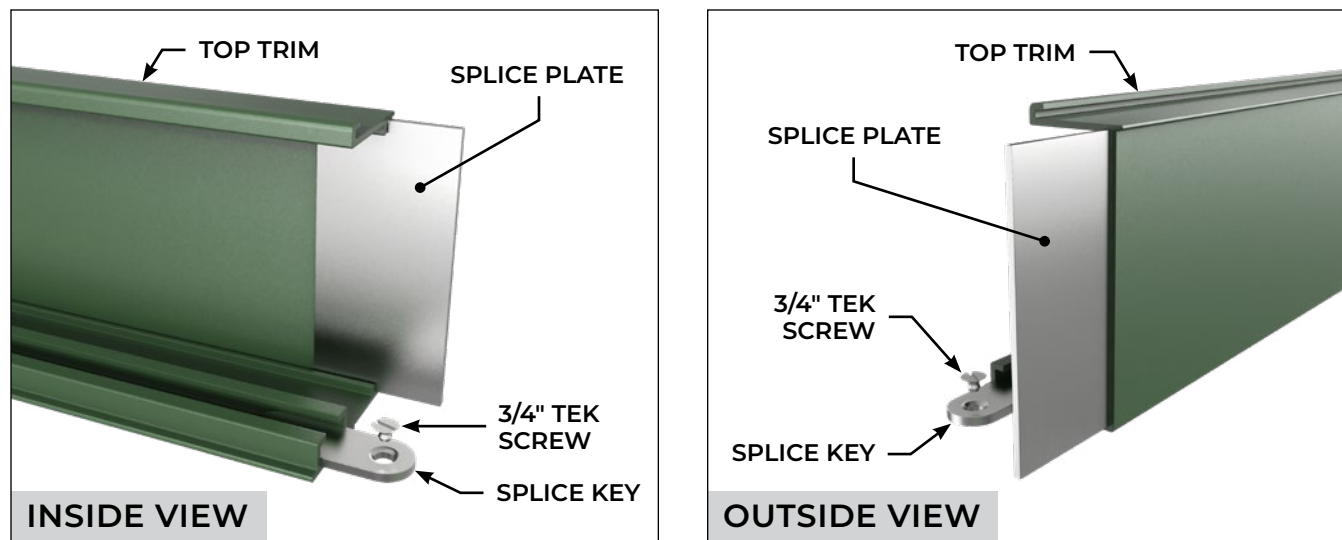

**Quick Tip:** Use an oil-based lubricant as needed to help assemble.

7. Attach the cut piece to the corner that is already installed on the **TOP RAIL**.

**7.1.** Line up the **SPLICES** with the screw grooves on the previously installed piece and slide into place.

**7.2.** Secure the **SPLICE KEYS** with two **3/4" TEK SCREWS** through the screw groove.

**7.3.** If needed, add additional **3/4" TEK SCREWS** every 12" through the screw groove.

8. Repeat steps 4-7 for the remaining **TOP TRIM** assembly and install.

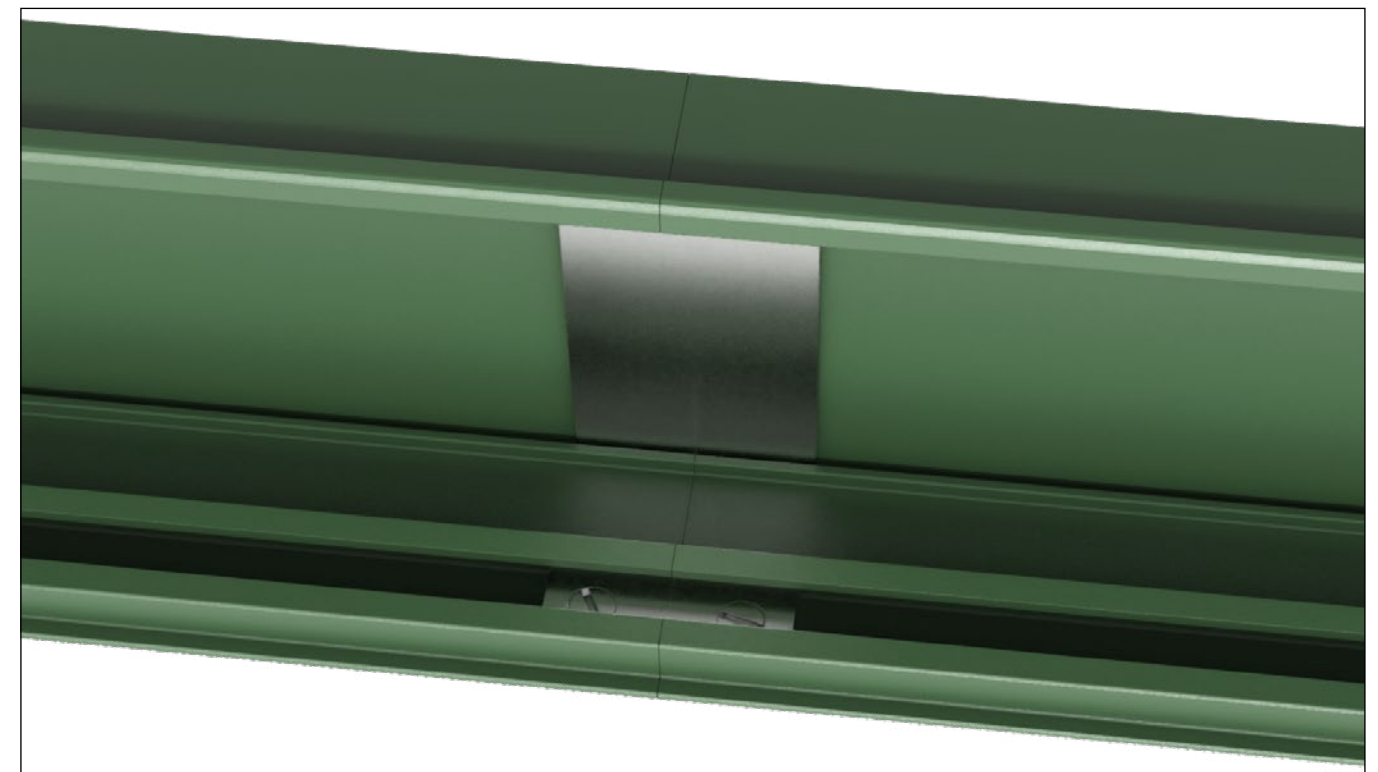

# TOP TRIM ASSEMBLY

## ALAMO & COVE

The **TOP TRIM** is fabricated from aluminum components and attaches to the **TOP RAIL** with **3/4" TEK SCREWS**.

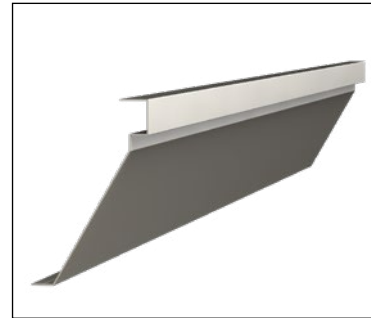

Alamo

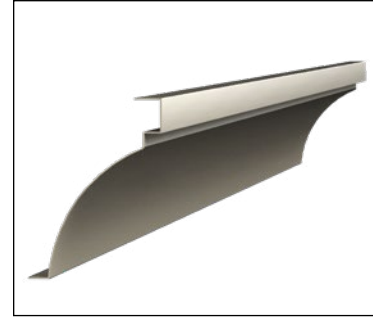

Cove

1. Position the **CORNER PIECE TOP TRIM** at each corner as required by the **Job Specific Submittal Drawings** and attach them to the **TOP RAIL** with **3/4" TEK SCREWS**. Measure the distance between the two **CORNER PIECE TOP TRIMS** before cutting the straight section of **TOP TRIM**.

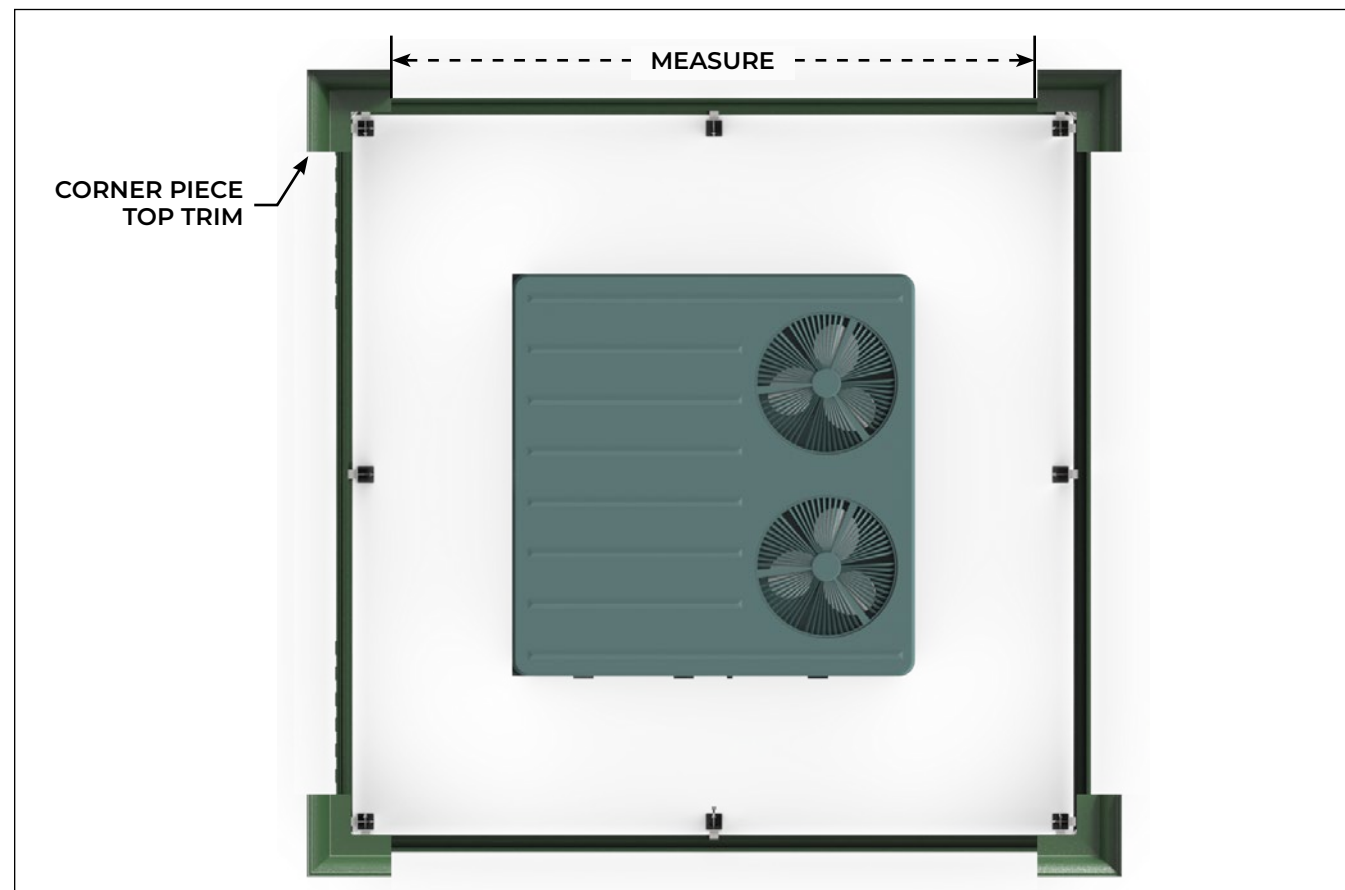

2. Join the straight section **TOP TRIM** with the **CORNER PIECE TOP TRIM** using the **(TOP) SPLICE KEY**, **(BOTTOM) SPLICE KEY** and **SPLICE PLATE**. Secure the **TOP KEY** and **BOTTOM KEY** with **3/4" TEK SCREWS**.
3. Repeat steps 1 and 2 on all remaining sides.

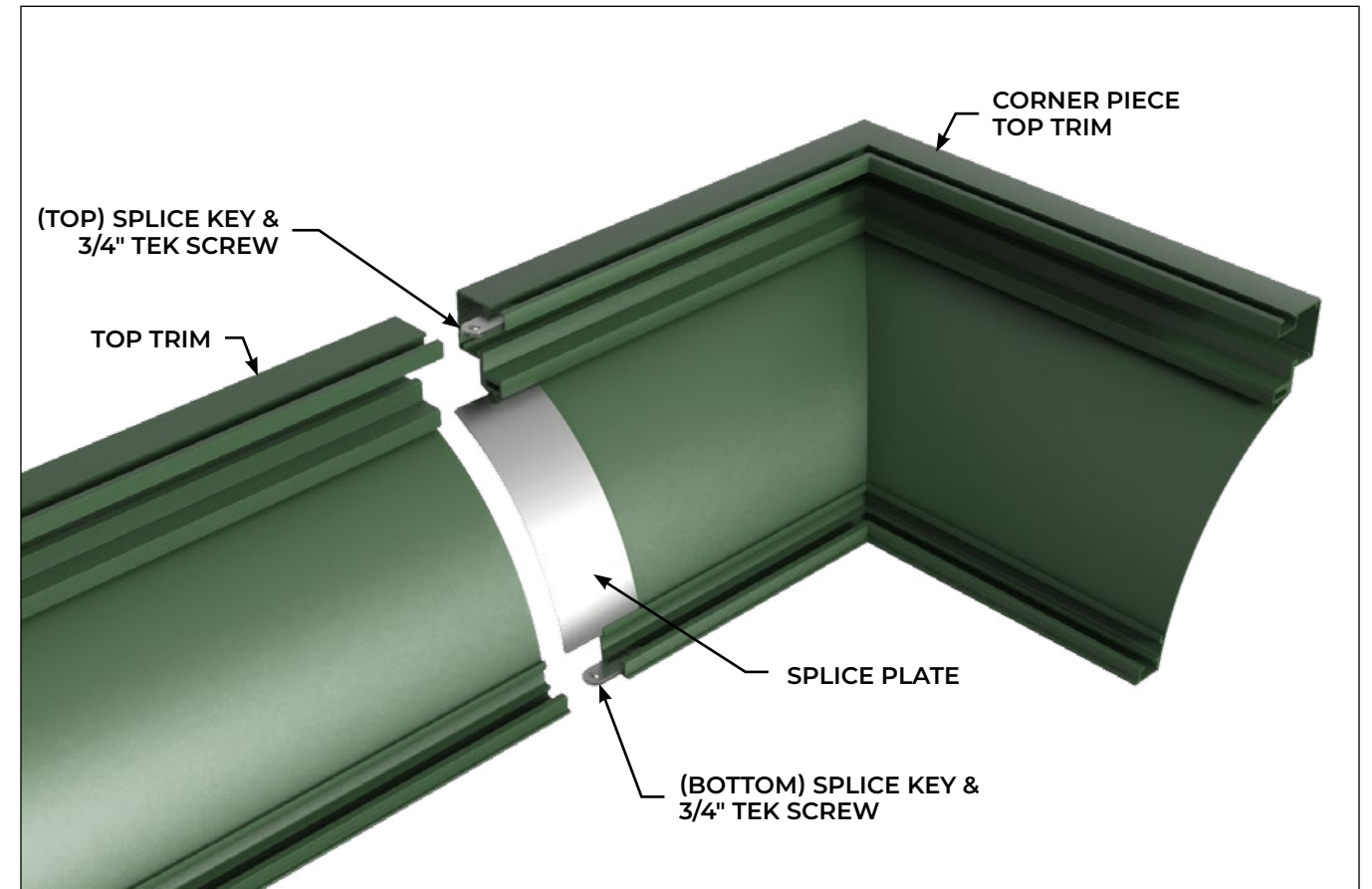

# STACKED SYSTEM INSTALL STEPS

When installing a stacked screen, follow the **Installation Instructions** starting with the top screen. When installing the bottom screen, the gap between the top rail and bottom rail should be 2".

**Note: Always reference the Job Specific Submittal Drawings for placement of brackets and Job Specific Parts.**

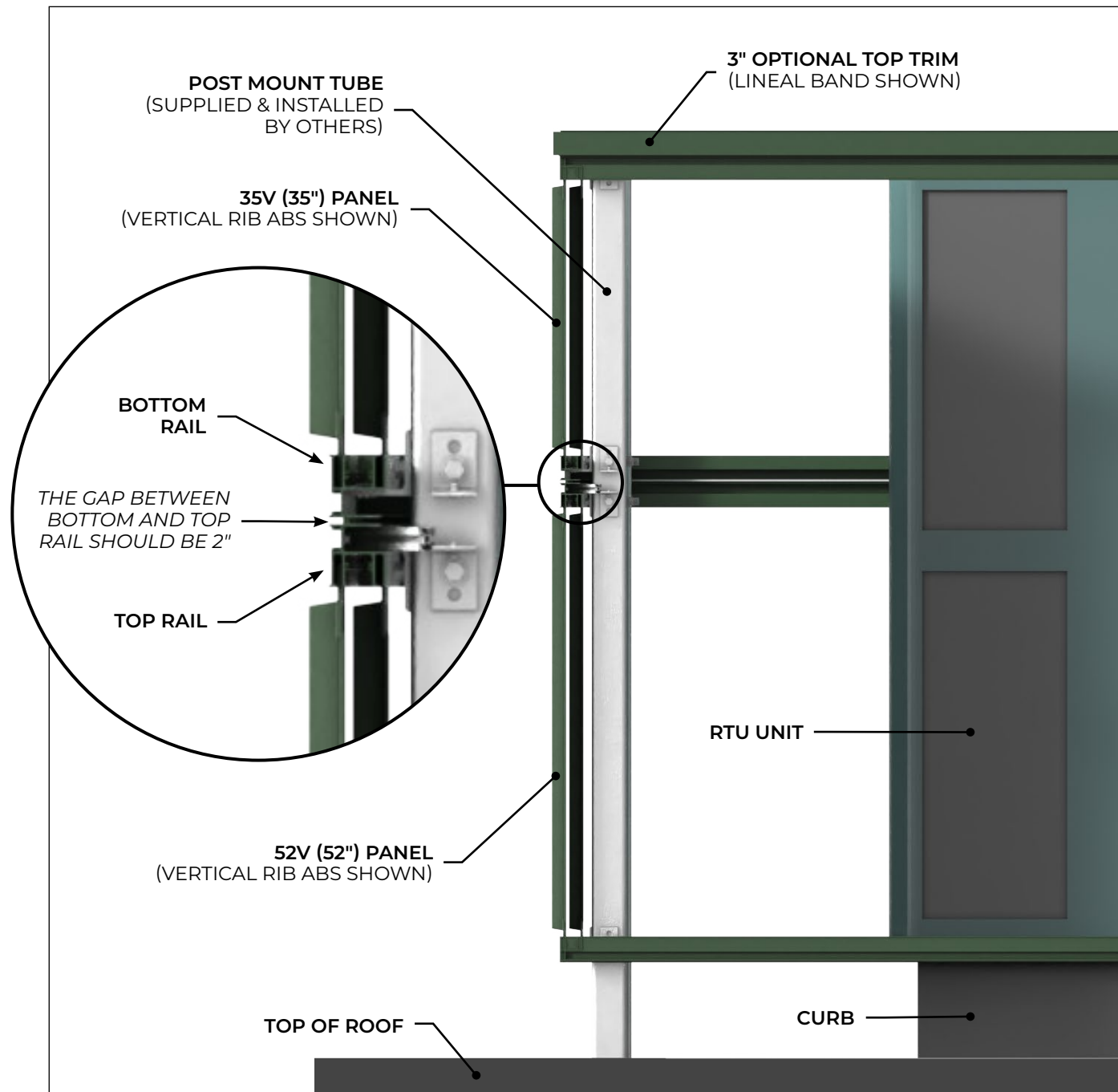

# GAP BRACE INSTALL STEPS

**Note: Always reference the Job Specific Submittal Drawings for placement of trusses and Job Specific Parts.**

## GAP BRACE PARTS:

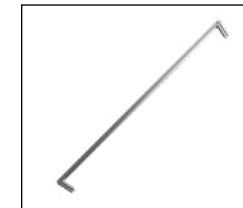

Aluminum Angle

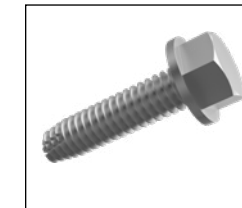

1" Hex Head Bolts (self-tapping/tapered)



3.5" X Frame

1. Connect one of the horizontal **X FRAME** pieces to each end of the **ALUMINUM ANGLE** using the **1" HEX HEAD BOLTS**.

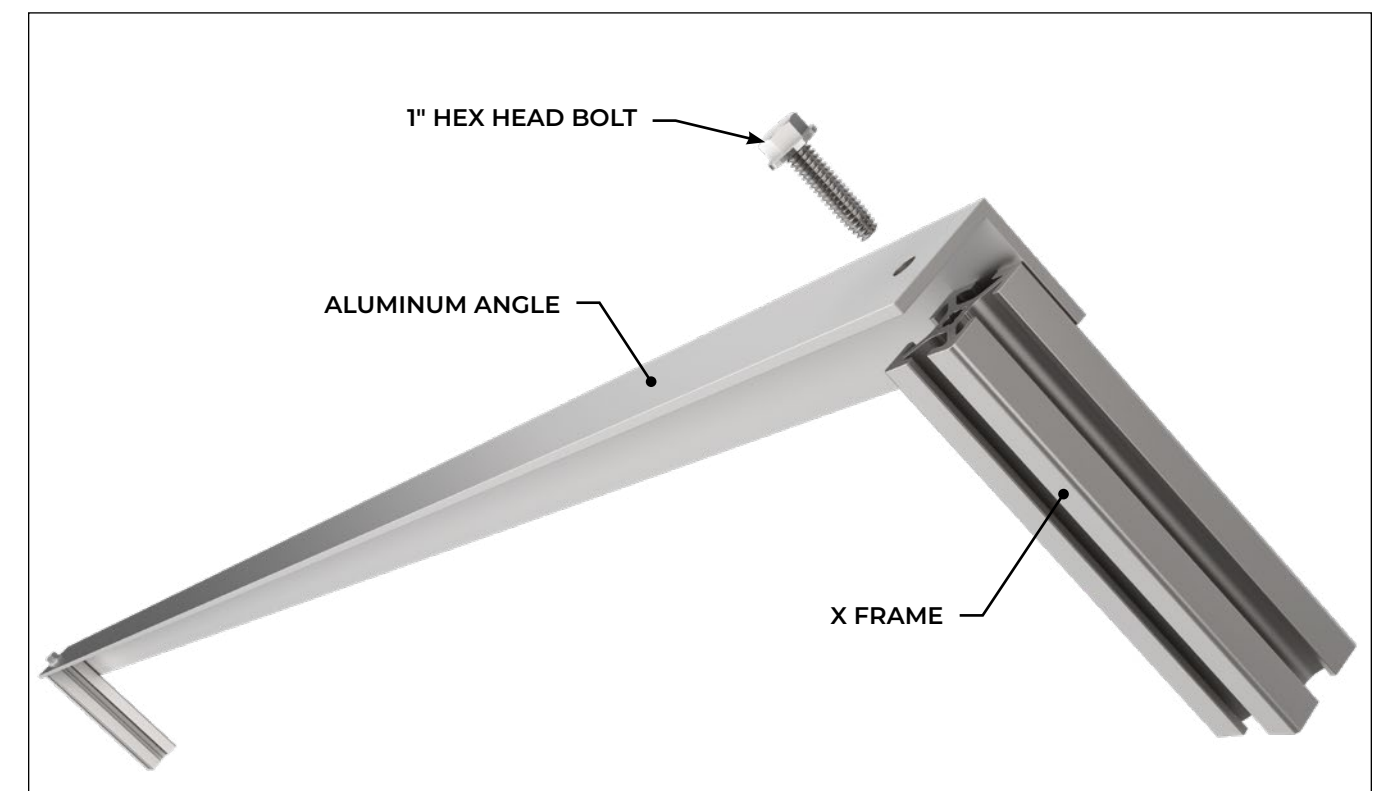

2. Mark the location of the pilot hole from the **X FRAME** extrusion onto the **BOTTOM RAIL** and **TOP RAIL** and drill a 5/16" hole.
3. Fasten 1" **HEX HEAD BOLTS** through **BOTTOM RAIL** and **TOP RAIL** into the **X FRAME** pilot hole.

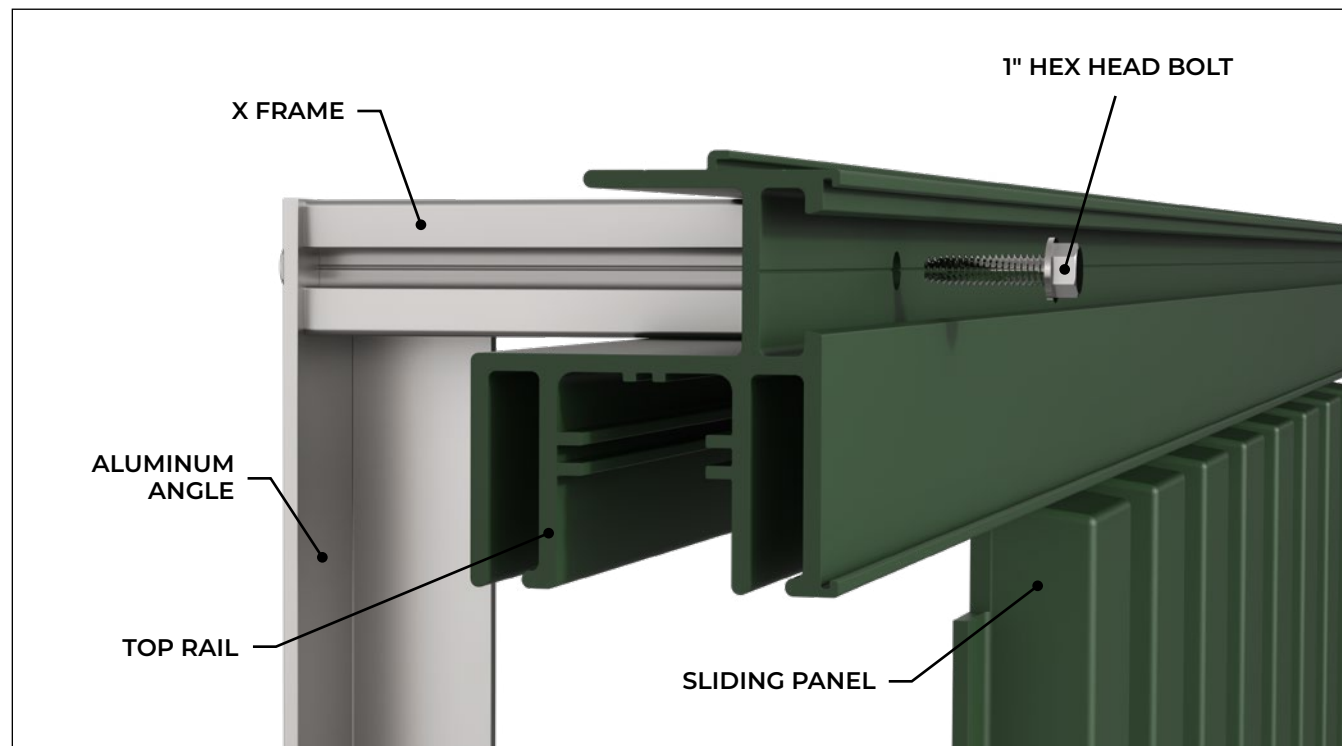
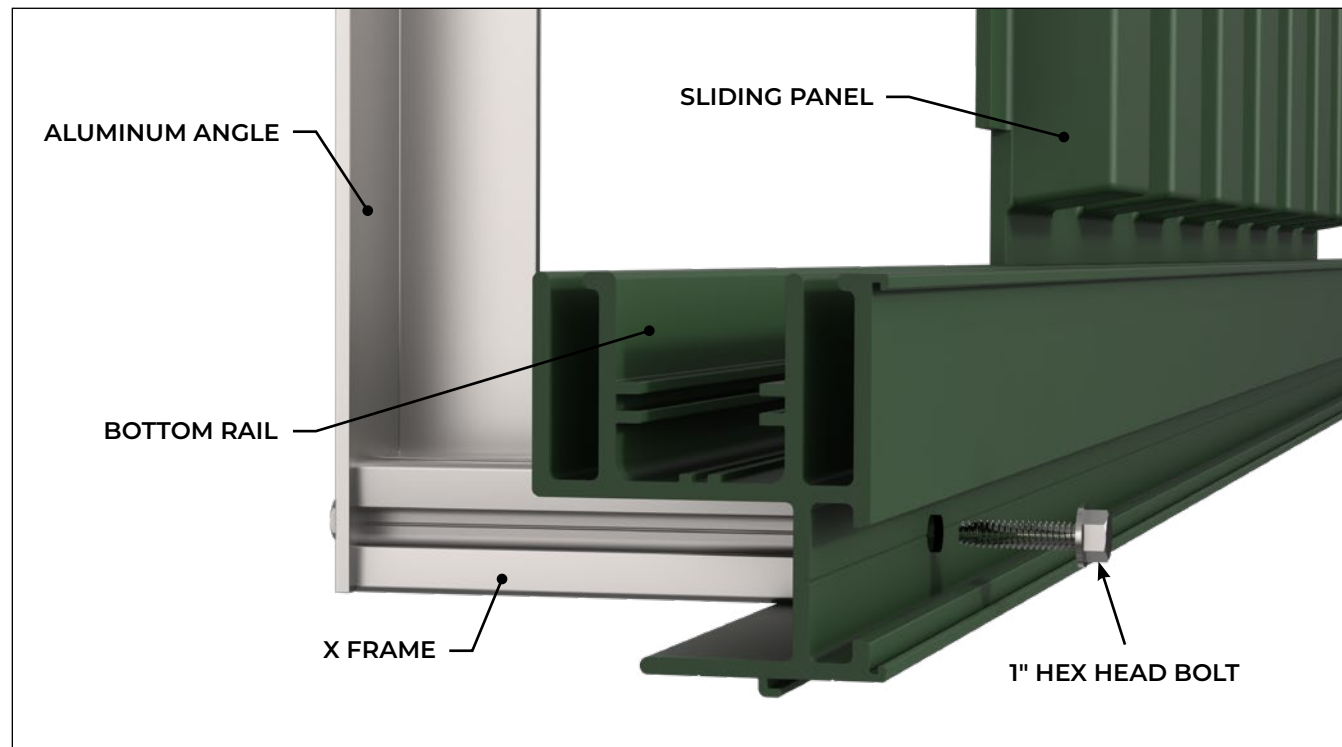

## POST MOUNTED INSTALL STEPS CONTINUED

7. Insert the **SLIDING PANELS** into the retainer channels of the **BOTTOM RAIL** according to the panel layout in the **Submittal Drawings**.

*Note: SLIDING PANELS are to be staggered between the inner and outer retainer channels, with the corner panels always in the outer channel.*

*The quantity and position of the SLIDING PANELS will vary across different screening applications. The overlap between the inner and outer panels will vary from approximately 2" to 6"*

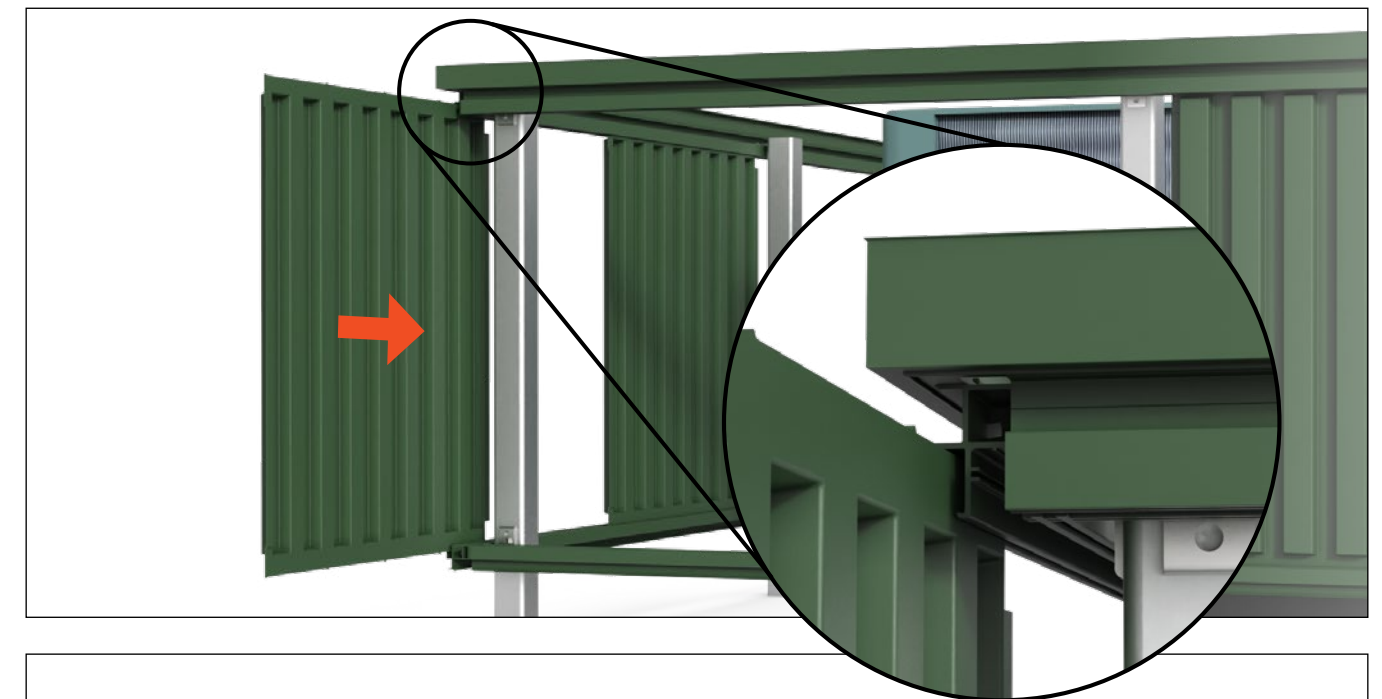

8. With all the **SLIDING PANELS** installed, begin at one corner with an **END CAP**, and position it flush over the ends of both the **TOP RAIL** and **BOTTOM RAIL**. Pre-drill pilot holes and use the **1 1/2" TEK SCREWS** to attach the **END CAP** to the **TOP** and **BOTTOM RAIL** extrusions at top and bottom.

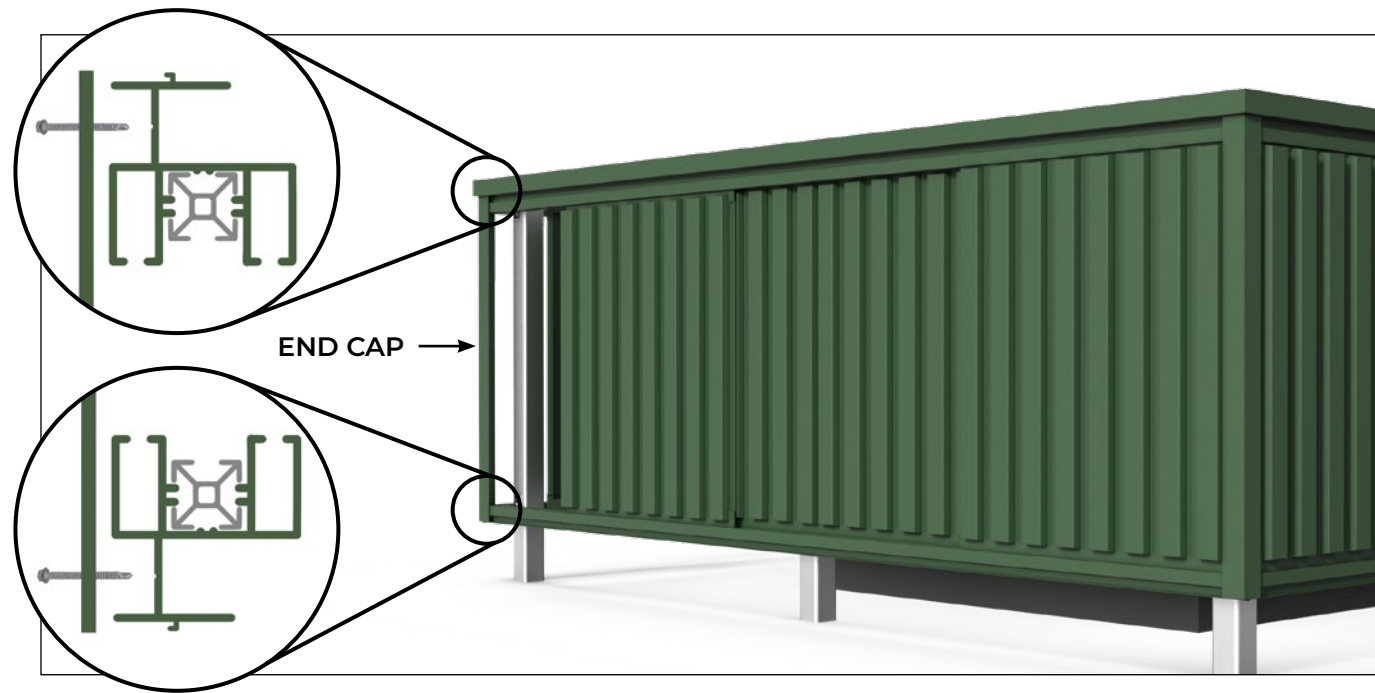

9. Place the **DISCONNECT STICKER** on the outside surface of the **SLIDING PANEL** that has the RTU's Disconnect Switch located behind it. Remove the backing from the label and apply it to this panel so that it is plain view.



10. Walk around the entire RTU screen to inspect and make any adjustments in the position of the panels. Adjust and move **SLIDING PANELS** left or right for even spacing to complete your installation.



11. Use the provided **TOUCH UP PAINT** in the same color as your Envisor® screen to cover exposed hardware and fix any small panel scratches.
12. Select a corner of the **BOTTOM RAIL** to place the **NAME PLATE**.
- 12.1. Center and level the **NAME PLATE**, mark the holes from the plate onto the **BOTTOM RAIL**.
- 12.2. Drill 1/8" holes at the marks.
- 12.3. Place two **DRIVE PIN RIVETS** into the drilled holes.
- 12.4. Hit heads of **DRIVE PIN RIVETS** to secure into structure.



# ANNUAL MAINTENANCE

---

## INSPECTION:

---

- ABS Panels – Visually inspect ABS panels. Replace panels if any sign of cracking or excess surface degradation appears
- Metal Panels – Visually inspect metal panels.
- Aluminum Components – Visually inspect all components for loose or missing hardware.
- Please call Customer Service at 877-727-3367 concerning infill panel or aluminum component replacement information.

## CLEANING:

---

- Clean panels with a mild detergent and water (a light washing is recommended)
- Clean debris from panel retainer tracks
-  **WARNING** – The use of petroleum-based oils, solvents, or paints on panels may produce minute cracks and/or discoloration on panel surface.

## PAINT TOUCH UP:

---

- Use manufacturer-supplied touch up paint as necessary.

# REPLACEMENT PART ORDERING

---

## ACRYLICAP® ABS SERIES PANEL SPECS:

---

- Acrylicap® uses .187 acrylic-capped ABS for UV protection
- All standard panels are 45" wide
- Standard panel heights are 35", 52", 70"
- Panels can be stacked for additional coverage
- Weight approximately 1.1lbs/sq ft

## METAL SERIES PANEL SPECS:

---

- Frames are 6063 T6 extruded aluminum
- Frame infill material thickness varies depending on infill choice
- Sherwin Williams 4000 Series Powder-Coated Components
- Pricing varies by panel style

TO ORDER CALL 877-727-3367

**CityScapesInc.com** | ARCHITECTURAL INNOVATIONS

ENVISOR® ROOFTOP SCREENING SYSTEMS - POST MOUNTED - INSTALLATION INSTRUCTIONS

EV-PM  
R20260505