

CityScapes[®]
ARCHITECTURAL
INNOVATIONS



ENVISOR[®]

A PATENTED ROOFTOP SCREENING SYSTEM

INSTALLATION INSTRUCTIONS - UNIT ATTACHED SYSTEM



(877) 727-3367

CITYSCAPESINC.COM

BIDS@CITYSCAPESINC.COM

BUILD AMERICA, BUY AMERICA ACT (BABAA) CERTIFIED

TABLE OF CONTENTS

4		System Overview
4		Getting Started
6		Parts & Components List
10		Unit-Attached System Exploded View
12		Corner Tube Truss Detail
13		Corner Tube Truss Assembly
15		Midspan Tube Truss Detail
16		Midspan Tube Truss Assembly
17		Casted-Connectors/Brackets Corner & Midspan Truss Detail and Assembly
19		Unit-Attached Install Steps
23		Rail Splice Install Steps
32		Top Trim Assembly – Lineal Band, 2-Step, & 3-Step
36		Top Trim Assembly – Alamo & Cove
38		Bottom Trim Assembly
40		Stacked System Install Steps
41		Gap Brace Install Steps
43		Alternate Post Support Install Steps
53		Annual Maintenance
54		Replacement Part Ordering

SYSTEM OVERVIEW

Envisor® components are designed to function as an Equipment Screening System. "Modular by Design" allows for a more user-friendly installation. This instruction manual is intended to communicate the "typical" Envisor® screen unit-attached installation. As you will see in the following pages, **rooftop units (RTUs)** vary greatly in size, performance accessories, and power supply requirements. Each screen ships as a knockdown assembly, with **Job Specific Submittal Drawings, Parts Lists** and **Instructions**. Please review these pages carefully. We encourage you to call or e-mail your questions and thank you for your interest in Envisor® equipment screens.

GETTING STARTED

If there are multiple RTUs, be sure to match the correct Envisor® screening components to the appropriate equipment. Component crates will be labeled with a **Sales Order Number**. All units have their own layout drawings included in the **Job Specific Submittal Packet** with the installation instructions. Review the area around the RTU for obstructions or supply lines that may interfere with the screening components during installation. If allowances were made for any field conditions prior to shipment, the **Job Specific Submittal Drawings** will identify equipment specific **CORNERS, MIDSPANS** or **EXTENSIONS** for your Envisor® screen(s).

NESTED SCREENS

If your Envisor® Screen is for a nested unit, consult the **Job Specific Submittal Drawings** for truss positions. **Confirm the RTUs are not on vibration/isolation curbs. If they are, contact your site manager and do not install.**



PLEASE NOTE THE FOLLOWING BEFORE STARTING INSTALLATION:

- Always reference the **Job Specific Submittal Package** you have been provided.
- Use **EXTREME CAUTION** when attaching these first components to the RTU with the stainless steel TEK screws.
- Some equipment may have mechanical operating elements directly behind the areas you are about to drive a screw into (i.e. condensing coils, power sources, etc.). **Be absolutely sure that you are not about to penetrate any of these elements.**
- Do not impede access to Service Doors or Disconnect Switches.

RECOMMENDED TOOLS FOR ASSEMBLY:









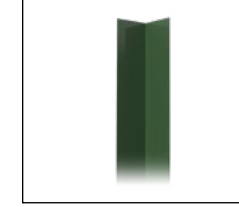

- Framing Square
- Level
- Tape Measure
- Cordless Drill
- Miter Saw
- Reciprocating Saw (with metal cutting blades)
- 5/16" Drill Socket (nut driver)
- 3/8" Combination Wrench
- 7/16" Combination Wrench
- 3/8" Socket
- 7/16" Socket
- 17/32" Drill Bit
- 1/8" Drill Bit
- 5/16" Drill Bit
- Quick Clamps (optional)

PARTS & COMPONENTS LIST

CORNER & MIDSPAN TRUSS KIT PARTS:

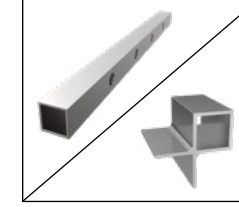
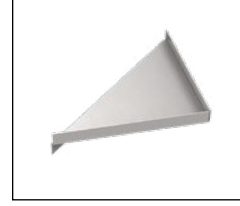
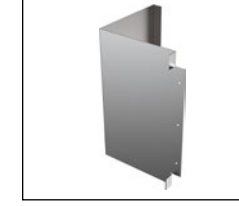
	X Frame		1 3/4" Hex Head Bolts (standard)
	Aluminum Angle		2" Hex Head Bolts (self-tapping/tapered)
	Strut Tube		1/4" Flat Washer
	1" Hex Head Bolts (self-tapping/tapered)		1/4" Lock Washer
	1/4" - 20 Hex Nut		#14 -14 x 1 1/4" TEK Screws
	1/4" Thick Rubber Spacers		Corner/Midspan Trusses with Casting Ends

MAIN SYSTEM PARTS:

	Top & Bottom Rail		Sliding Panels
	Brace Rail (6" X Frame)		End Cap
	#14-14 x 1 1/4" TEK Screws		#12-14 x 1 1/2" TEK Screws
	Stabilizer Brace		Extension Tubes (Varies in Style & Size)
	Gusset (Optional)		Extension Corner (Optional; Varies in Size)
	Extension Midspan (Optional; Varies in Size)		1 3/4" Hex Head Bolt (standard)
	1/4" Flat Washer		1/4" Nylock Nut

RAIL SPLICE KIT (STANDARD):

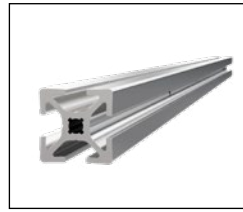

Splice (16" X Frame)



2" Hex Head Bolts
(Standard)



1/4" Flat Washers



1/4" Lock Washer

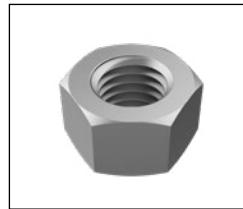

1/4"-20 Hex Nut

RAIL SPLICE KIT (QUICK RELEASE):



Splice (16" X Frame)



Quick Release Pins
(Submittal Specific Part)

TOP TRIM PARTS:

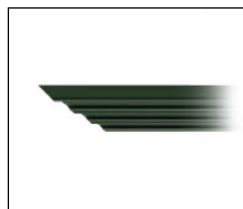

Left Top Trim

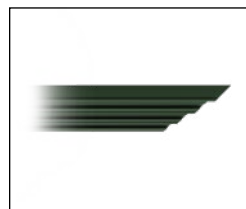

Right Top Trim



Splice Key



Corner Key

Quick Tip: Use an oil-based lubricant as needed to help assemble.

TOP TRIM PARTS CONTINUED:

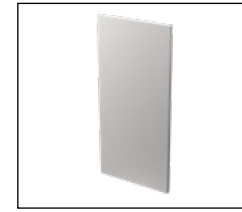

Splice Plate

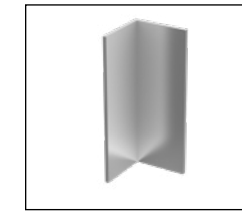

Corner Tab



Trim Corner
(for Alamo and Cove
Trim Styles Only)

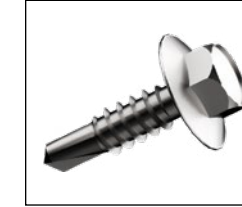

#10-16 x 3/4"
TEK Screws

BOTTOM TRIM PARTS:

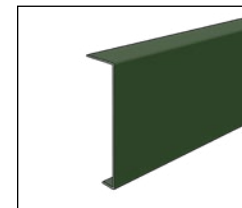

Bottom Trim

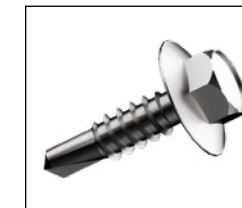

#10-16 x 3/4"
TEK Screws

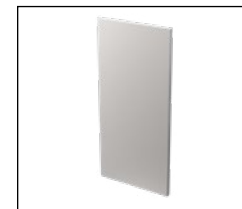

Splice Plate

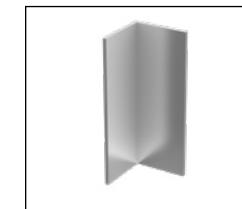

Corner Tab

ADDITIONAL PARTS:



Disconnect Sticker



Touch Up Paint



Name Plate



Drive Pin Rivet 1/8" x
1/8" Stainless Steel

ENVISOR® EXPLODED VIEW

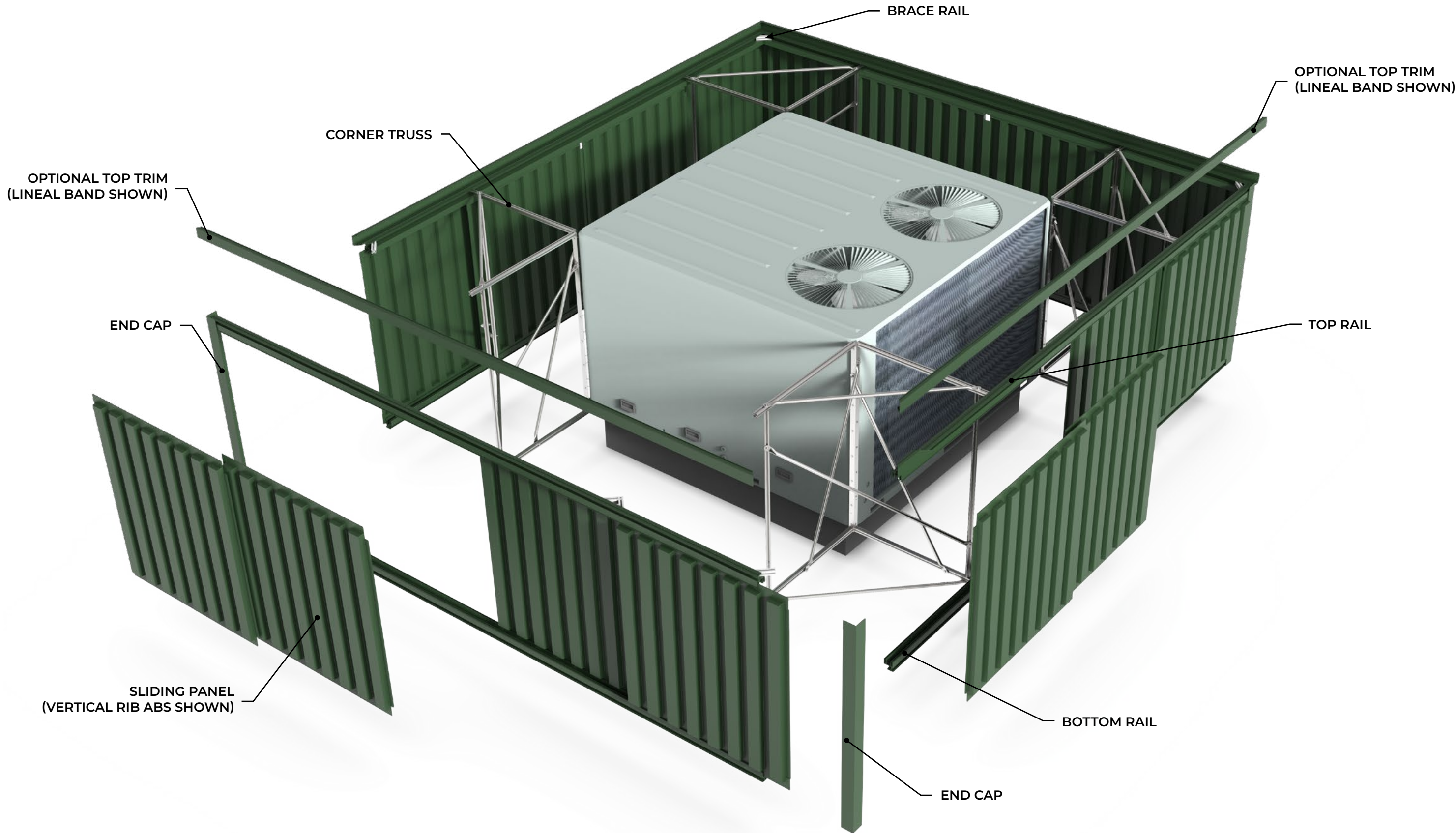

CORNER TUBE TRUSS DETAIL

CORNER TRUSS EXPLODED VIEW

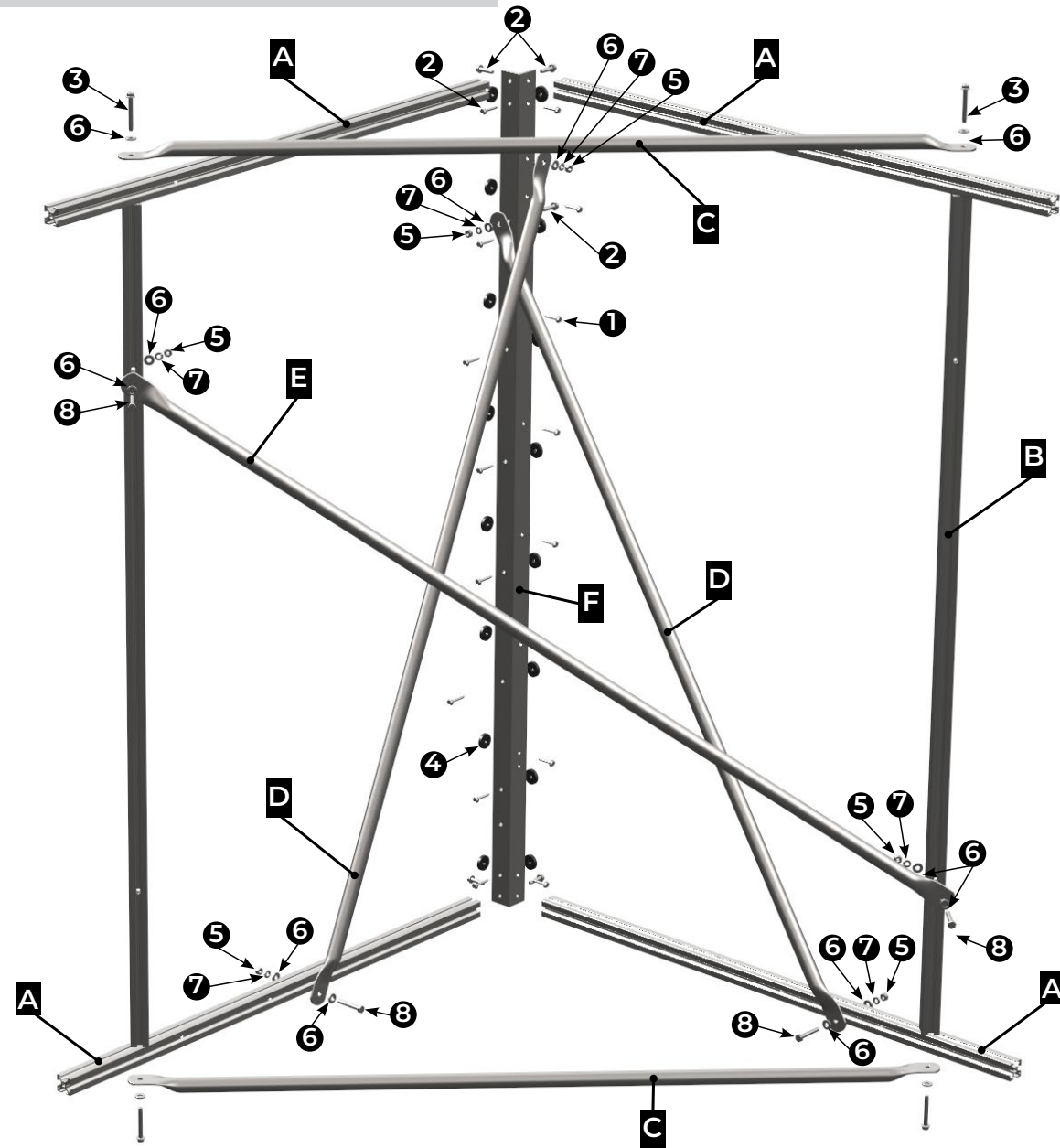

PART LIST					
ITEM	DESCRIPTION	QTY	ITEM	DESCRIPTION	QTY
A	X FRAME (HORIZONTAL)	4	1	1-1/4" TEK SCREW	16
B	X FRAME (VERTICAL)	2	2	1" HEX HEAD BOLT	6
C	STRUT TUBE	2	3	2" HEX HEAD BOLT	4
D	STRUT TUBE	2	4	1/4" RUBBER SPACER	16
E	STRUT TUBE	1	5	1/4" HEX NUT	6
F	ALUMINUM ANGLE	1	6	1/4" FLAT WASHER	16
			7	1/4" LOCK WASHER	6
			8	1-3/4" HEX HEAD BOLT	4

CORNER TUBE TRUSS ASSEMBLY

1. Using the **1" HEX HEAD BOLTS** and a **FLAT WASHER**, connect the **HORIZONTAL X FRAME [A]** to the **ALUMINUM ANGLE [F]** at the top and bottom. Use the **VERTICAL X FRAMES [B]** as spacers to ensure the height of the corner frame is correct. The bolt should go into the back of the **ALUMINUM ANGLE [F]** and through the center hole of the **HORIZONTAL X FRAME [A]**.
 - 1.1. Repeat for all four **HORIZONTAL X FRAMES [A]**.
2. Span the gap between the top **HORIZONTAL X FRAMES** with a **STRUT TUBE [C]**. Using the **2" HEX HEAD BOLTS** and **FLAT WASHERS**, secure these through the top of the **HORIZONTAL X FRAMES** and into the **VERTICAL X FRAME** supports.
3. Repeat step 2 for the bottom **STRUT TUBE [C]** cross member support.

CORNER TRUSS ASSEMBLED VIEW

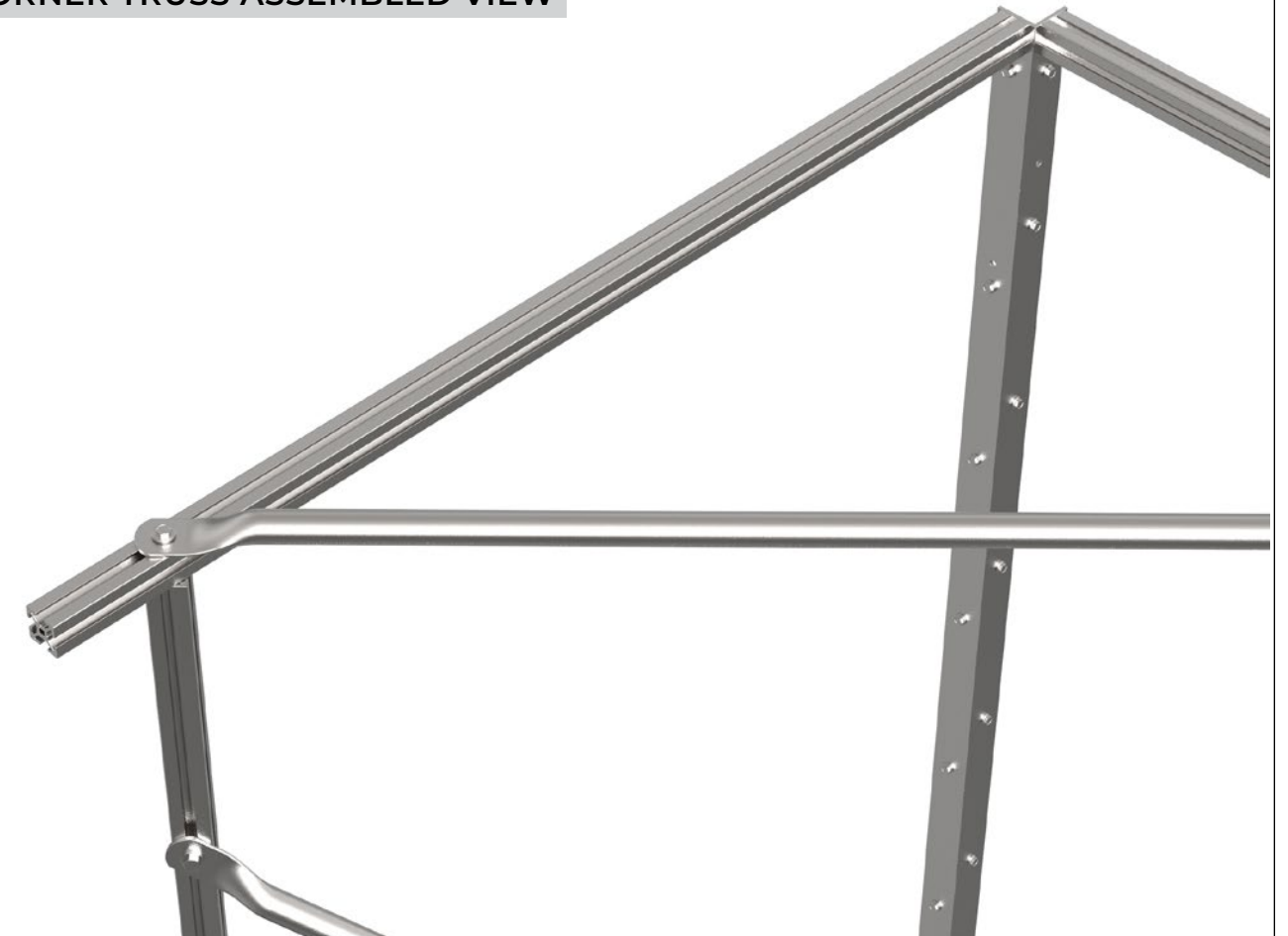

4. Using the **1" HEX HEAD BOLTS, FLAT WASHERS, LOCK WASHERS** and **HEX NUTS**, secure one end of the **STRUT TUBES** to the **ALUMINUM ANGLE**.
5. Connect the other ends of the **STRUT TUBES** to the Bottom **X FRAMES** using the **1 3/4" HEX HEAD BOLTS, FLAT WASHERS, LOCK WASHERS** and **HEX NUTS**.
6. Attach a **STRUT TUBE** between the vertical **X FRAMES** using the **1 3/4" HEX HEAD BOLTS, FLAT WASHERS, LOCK WASHERS** and **HEX NUTS**.
7. Remove paper backing from the **RUBBER SPACERS**, align and adhere them to each hole on the back of the **ALUMINUM ANGLE**. *These are needed to ensure proper spacing and vibration insulation of the Envisor® screen from the rooftop unit (RTU).*



MIDSPAN TUBE TRUSS DETAIL

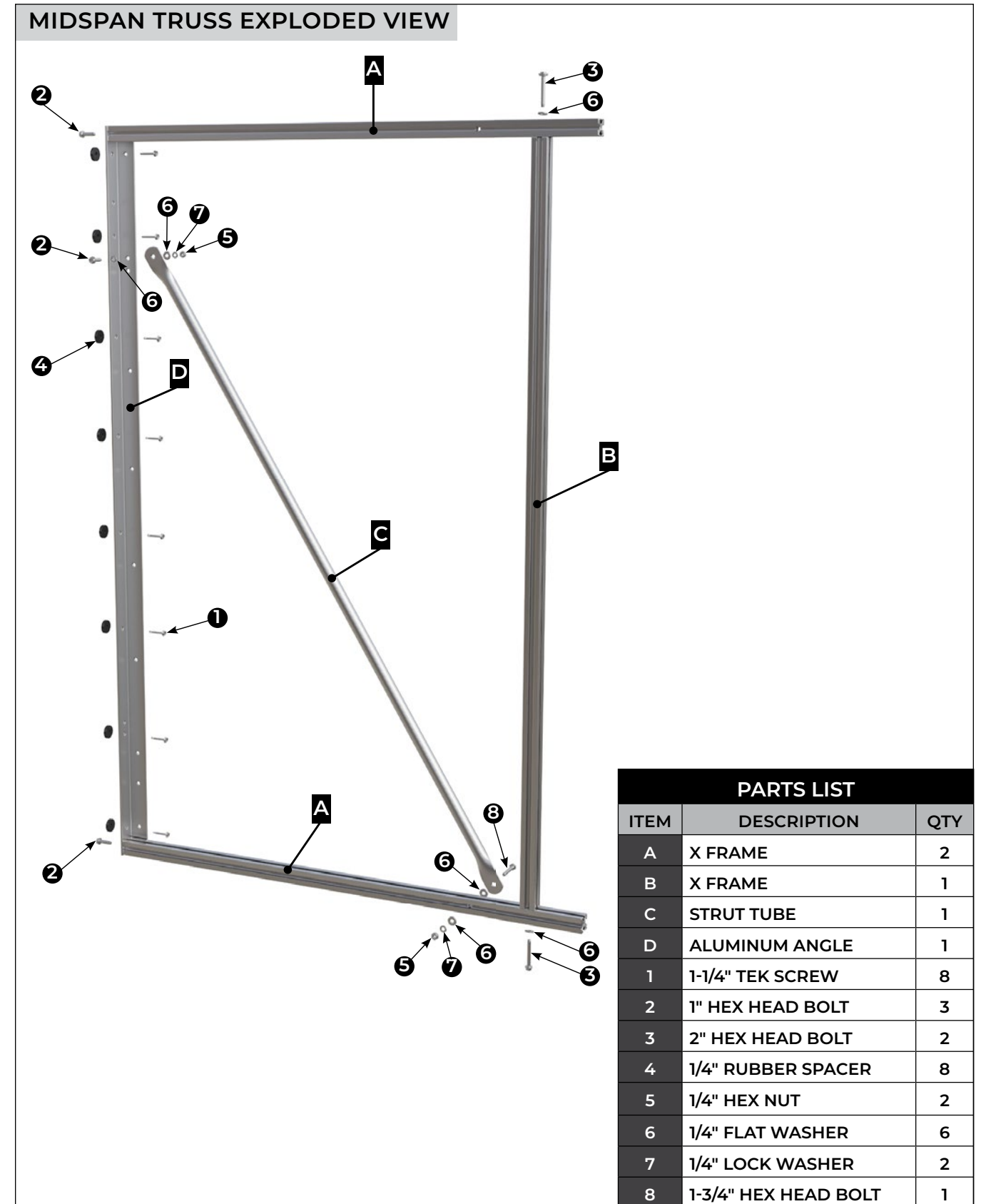

MIDSPAN TUBE TRUSS ASSEMBLY

1. Connect one of the horizontal **X FRAME** pieces to the **ALUMINUM ANGLE** using the **1" HEX HEAD BOLTS**.
2. Connect the other horizontal **X FRAME** pieces to the vertical **X FRAME** using the **2" HEX HEAD BOLTS, FLAT WASHERS,** and **LOCK WASHERS**.
3. Align and connect the two pieces, making sure the parts are square before tightening.
4. Connect one end of the **STRUT TUBE** to the **ALUMINUM ANGLE** using the **1" HEX HEAD BOLTS, FLAT WASHERS, LOCK WASHER,** and **HEX NUT**.
5. Connect the other end of the **STRUT TUBE** to the bottom **X FRAME** using the **1 3/4" HEX HEAD BOLTS, FLAT WASHERS, LOCK WASHER,** and **HEX NUT**.
6. Remove paper backing from the **RUBBER SPACERS**, align and adhere them to each hole on the back of the **ALUMINUM ANGLE**. *These are needed to ensure proper spacing and vibration insulation of the Envisor® screen from the RTU.*

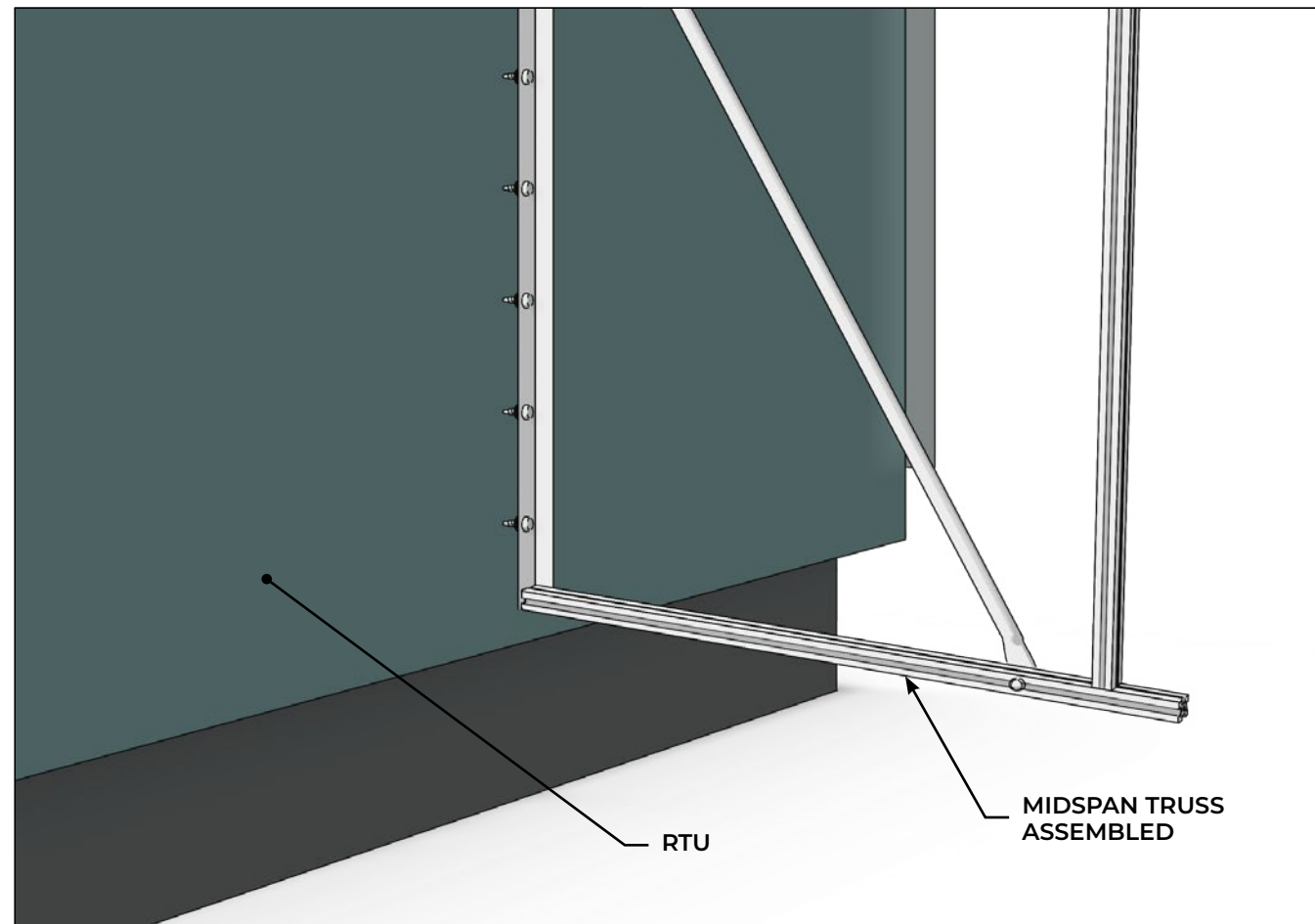

CAST-CONNECTORS/BRACKETS CORNER & MIDSPAN TRUSS DETAILS AND ASSEMBLY

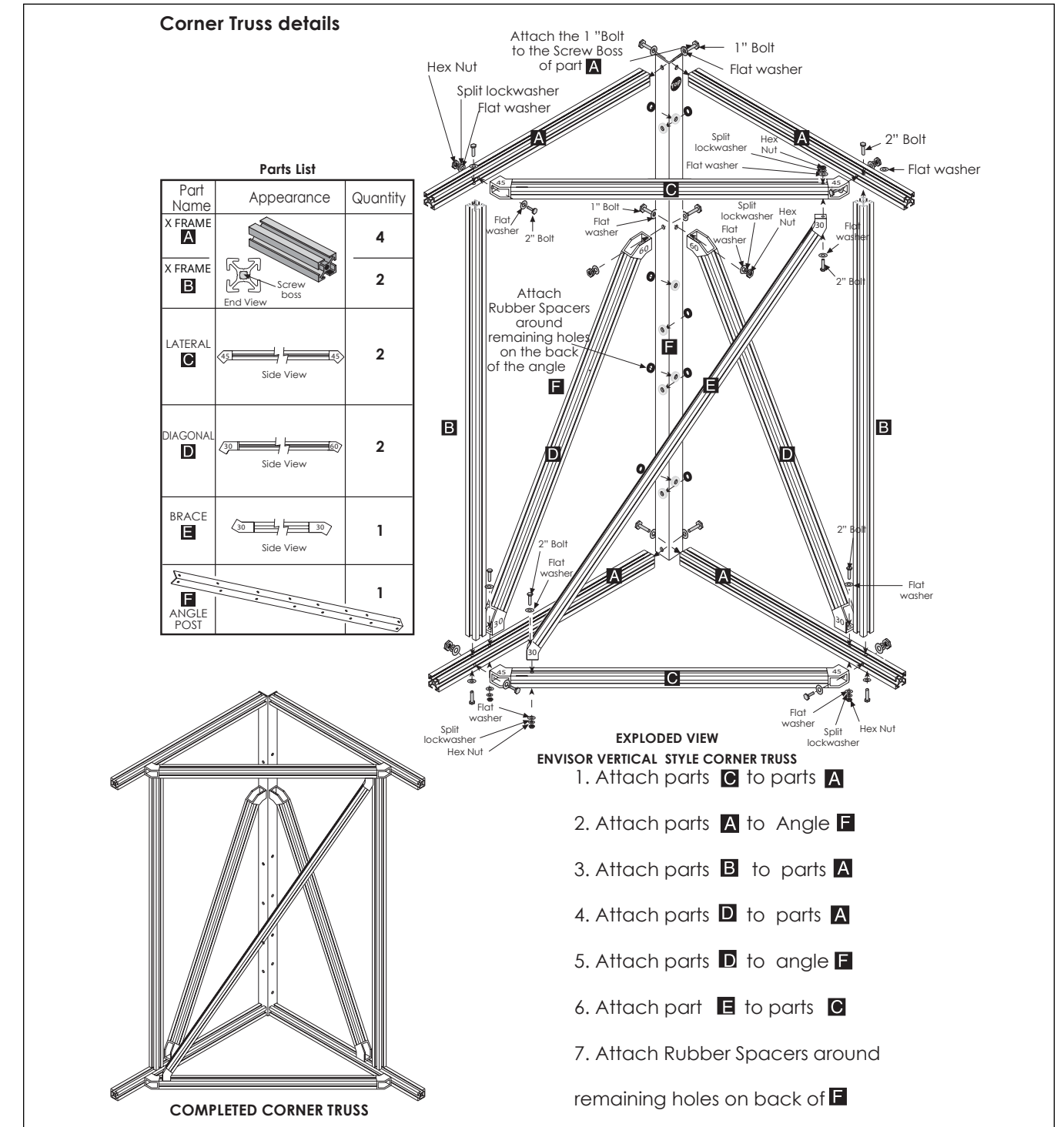

Midspan Truss details

Parts List

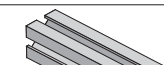
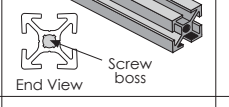
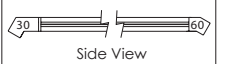
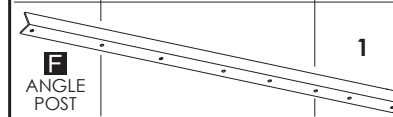
Part Name	Appearance	Quantity
X FRAME A		2
X FRAME B		1
DIAGONAL D		1
ANGLE POST F		1

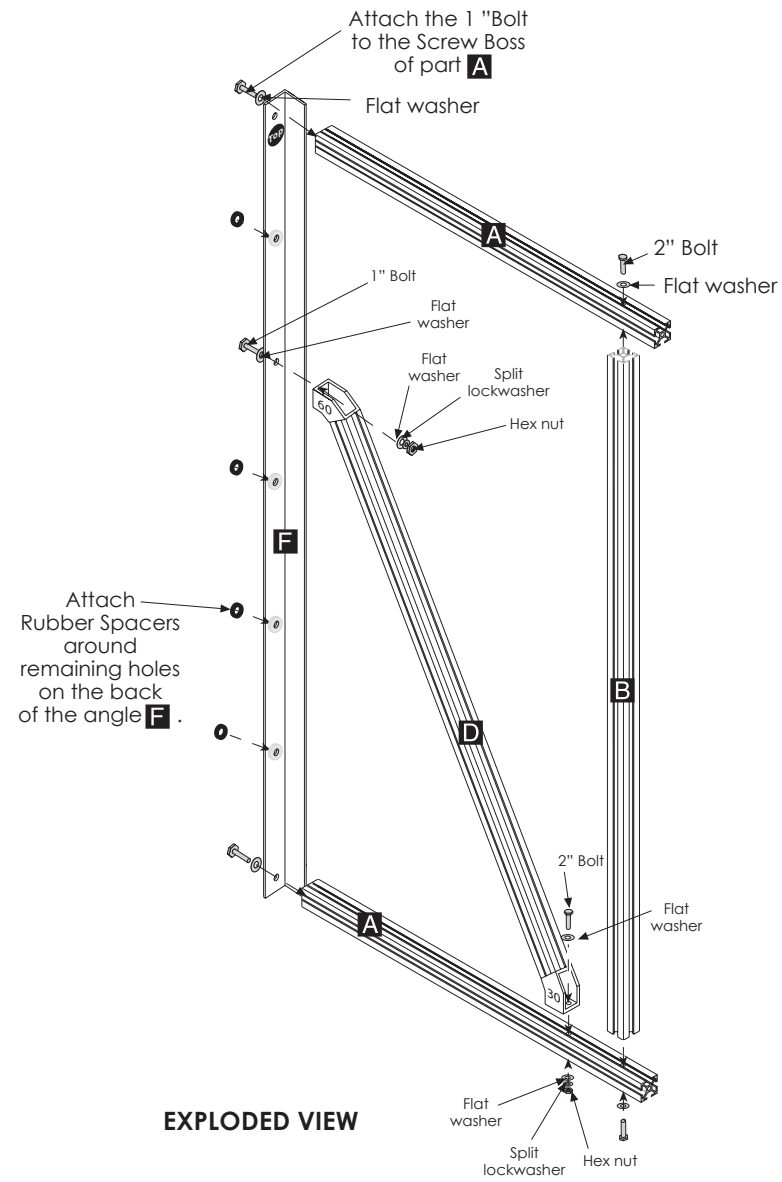

EXPLODED VIEW

1. Attach parts **A** to Angle **F**
2. Attach part **B** to parts **A**
3. Attach part **D** to part **A**
4. Attach part **D** to angle **F**
5. Attach Rubber Spacers around remaining holes on back of **F**

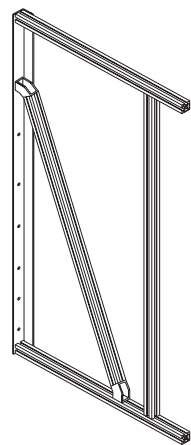

COMPLETED
MIDSPAN TRUSS

UNIT-ATTACHED INSTALL STEPS

1. Check the **Job Specific Submittal Drawings** for any required **EXTENSION TUBES, EXTENSIONS** or **GUSSETS**.
 - 1.1. First install the **EXTENSION TUBES** or **EXTENSION FISH TUBES**, then sheet metal **EXTENSIONS** and **GUSSETS**, then **TRUSSES**.
 - 1.2. Make sure all parts are in the correct locations as shown in the **Submittal Drawings** before attaching **TRUSSES**.

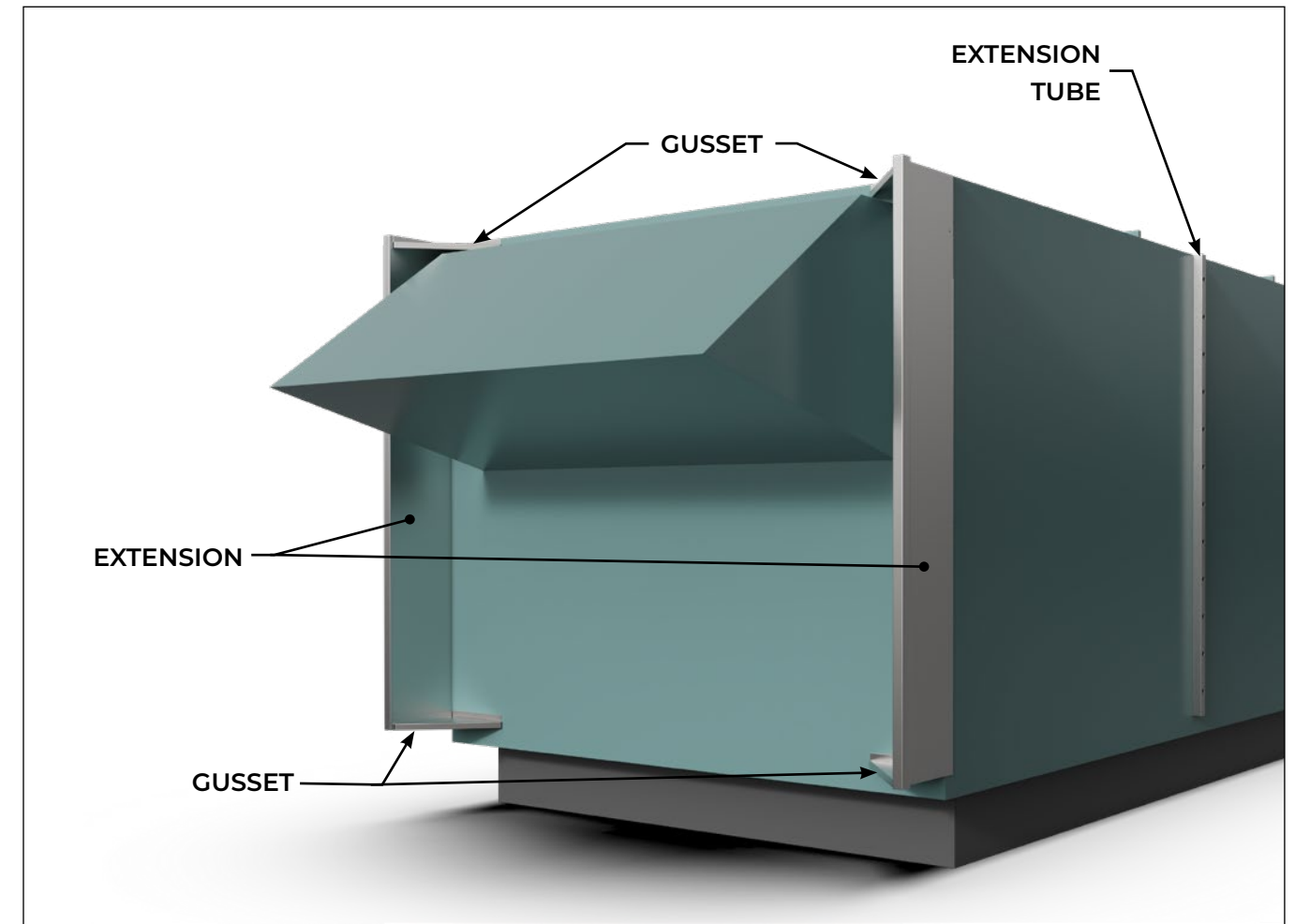

2. Build **CORNER TRUSSES** and **MIDSPAN TRUSSES** according to the instructions provided. See pages 12-18.

3. Starting at one corner, align a **CORNER TRUSS** with the RTU. Mount it by inserting **1 1/4" TEK SCREWS** through the **ALUMINUM ANGLE** and **RUBBER SPACERS**, and into the RTU. *If needed, the TRUSS can extend above the cabinet a maximum of 4".*

Note: Refer to the Job Specific Submittal Drawings for placement of TRUSSES and Job Specific Parts.

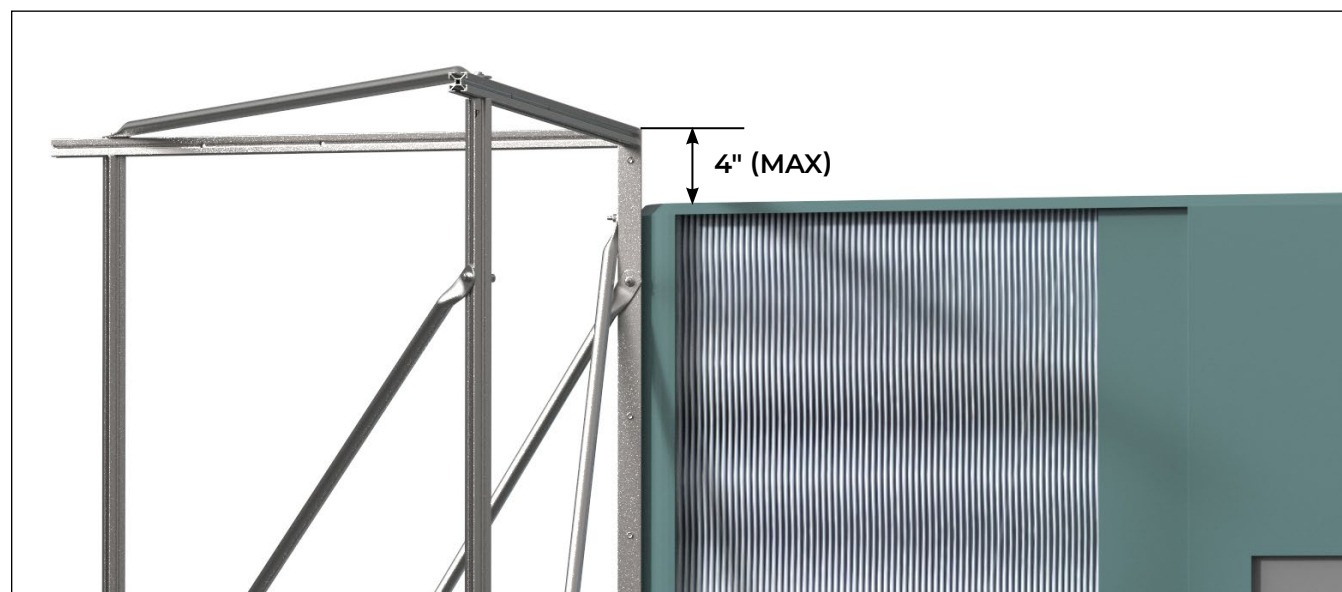
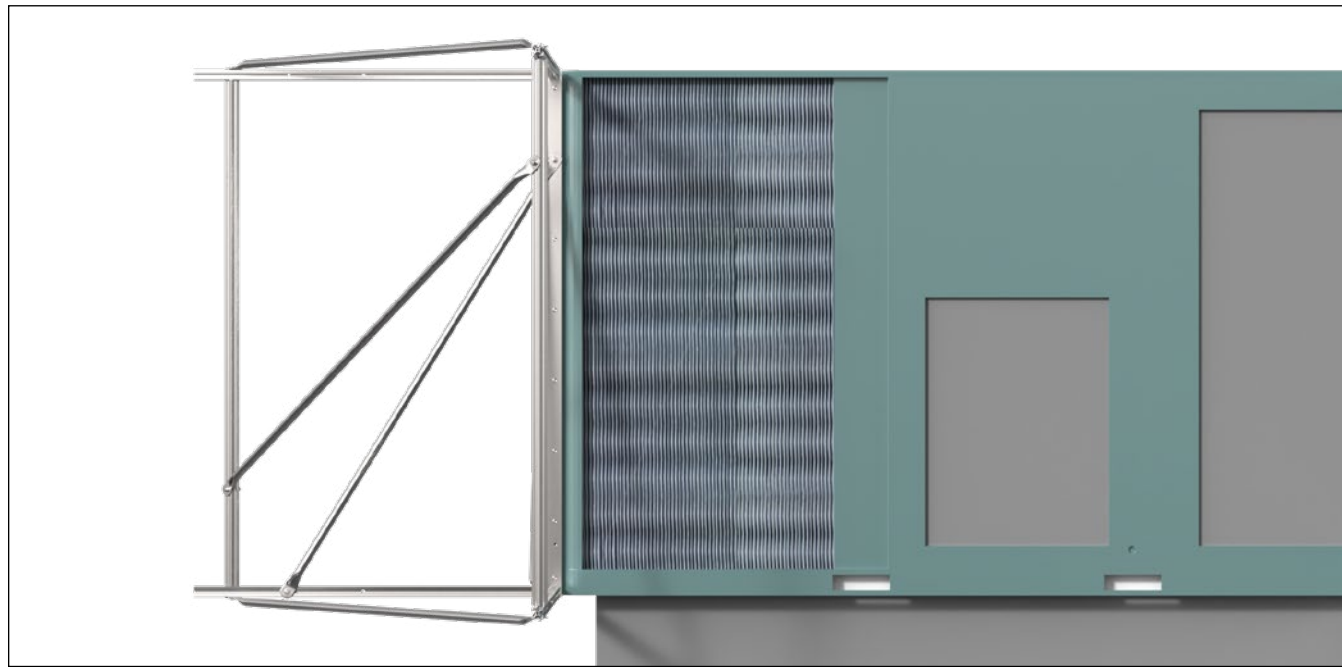

4. Repeat **step 3** for a second **CORNER TRUSS**.

4.1. Use a **BOTTOM RAIL** to level the span between the two corners.

4.2. Adjust the vertical position of the second **CORNER TRUSS** to keep the **BOTTOM RAIL** level.

5. While the **BOTTOM RAIL** is still in place, mount any required **MIDSPAN TRUSSES** by inserting **1 1/4" TEK SCREWS** through the **ALUMINUM ANGLE** and **RUBBER SPACERS**, and into the side of the RTU.



6. Work your way around the unit in this manner to install the remaining **CORNER TRUSSES** and **MIDSPAN TRUSSES**.

Note: Refer to the Job Specific Submittal Drawings for placement of MIDSPAN TRUSSES for both Single and Nested Units.

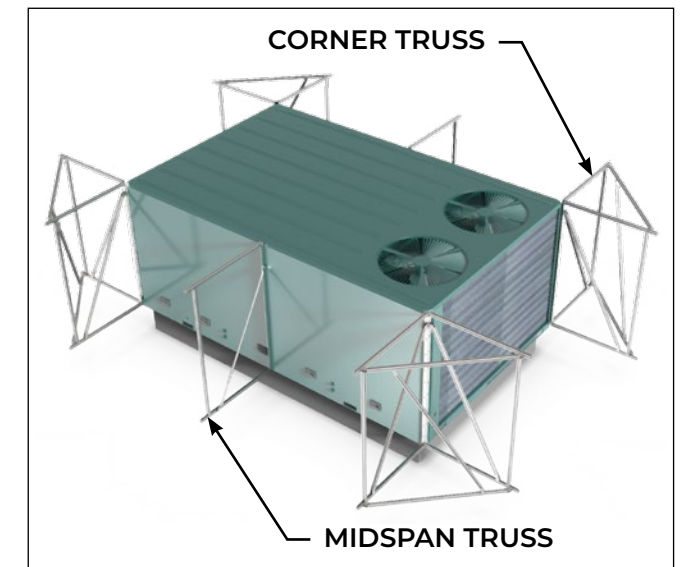
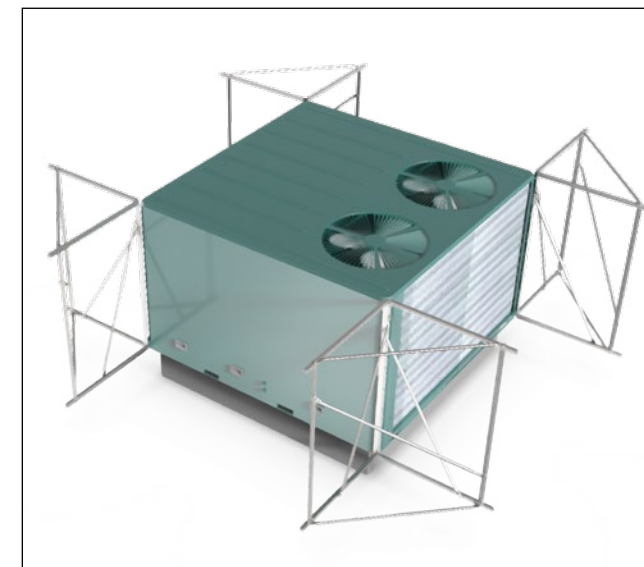

7. Temporarily align all **BOTTOM RAILS**, keeping all 4 corners of **BOTTOM RAILS** square to each other and fit onto the protrusions of the **CORNER TRUSSES**. If any of the dimensions on your RTU are longer than the longest **BOTTOM RAIL**, you will need to splice two lengths together with the **SPLICE KIT** provided.

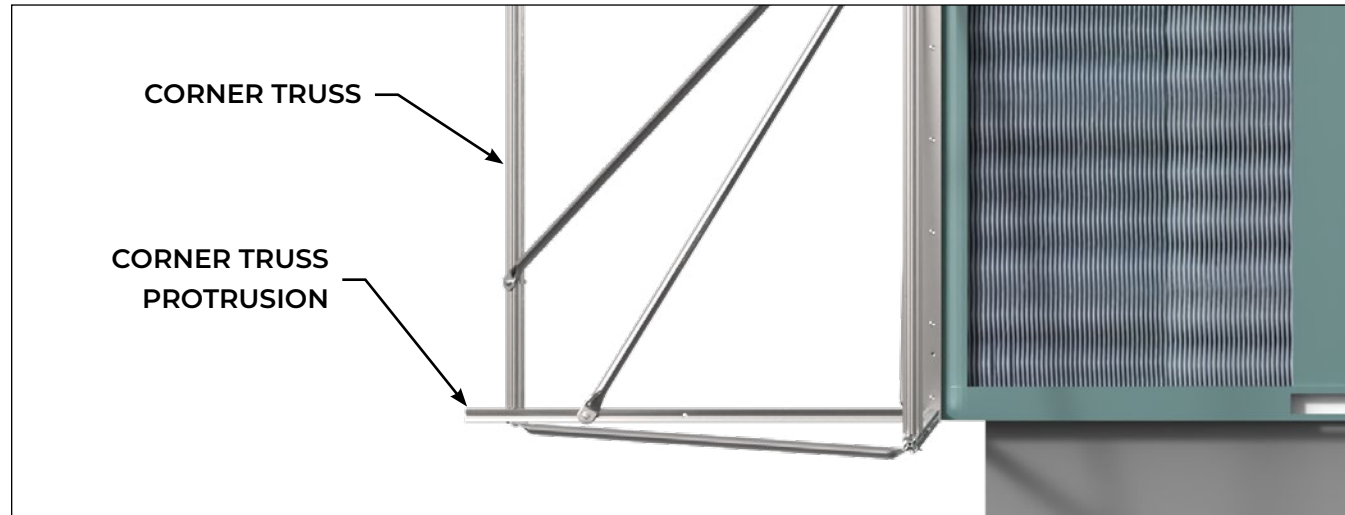

If the Job Specific Submittal Packet includes a RAIL SPLICE KIT, go to the RAIL SPLICE INSTALL STEPS on page 23.

Otherwise, continue with the main UNIT-ATTACHED INSTALL STEPS on page 27.

RAIL SPLICE INSTALL STEPS

RAIL SPLICE KIT (STANDARD):



Splice (16" X Frame)



2" Hex Head Bolts (Standard)



1/4" Flat Washers



1/4" Lock Washer

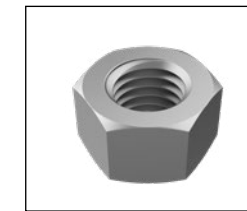

1/4"-20 Hex Nut

RAIL SPLICE KIT (QUICK RELEASE):



Splice (16" X Frame)



Quick Release Pins (Submittal Specific Part)

BILL OF MATERIAL			
ITEM	REQ	PART#	DESCRIPTION
1	1	80000156	1 1/8" X 1 1/8" FRAME EXTRUSION 16" LG.
2	4	12500028	BOLT HEX HD 1/4-20 X 2 SS
3	8	12500007	1/4"-20 FLAT WASHER SS
4	4	12500006	1/4"-20 HEX NUT SS
5	4	12500008	WASHER SPLIT LOCK 1/4 SS

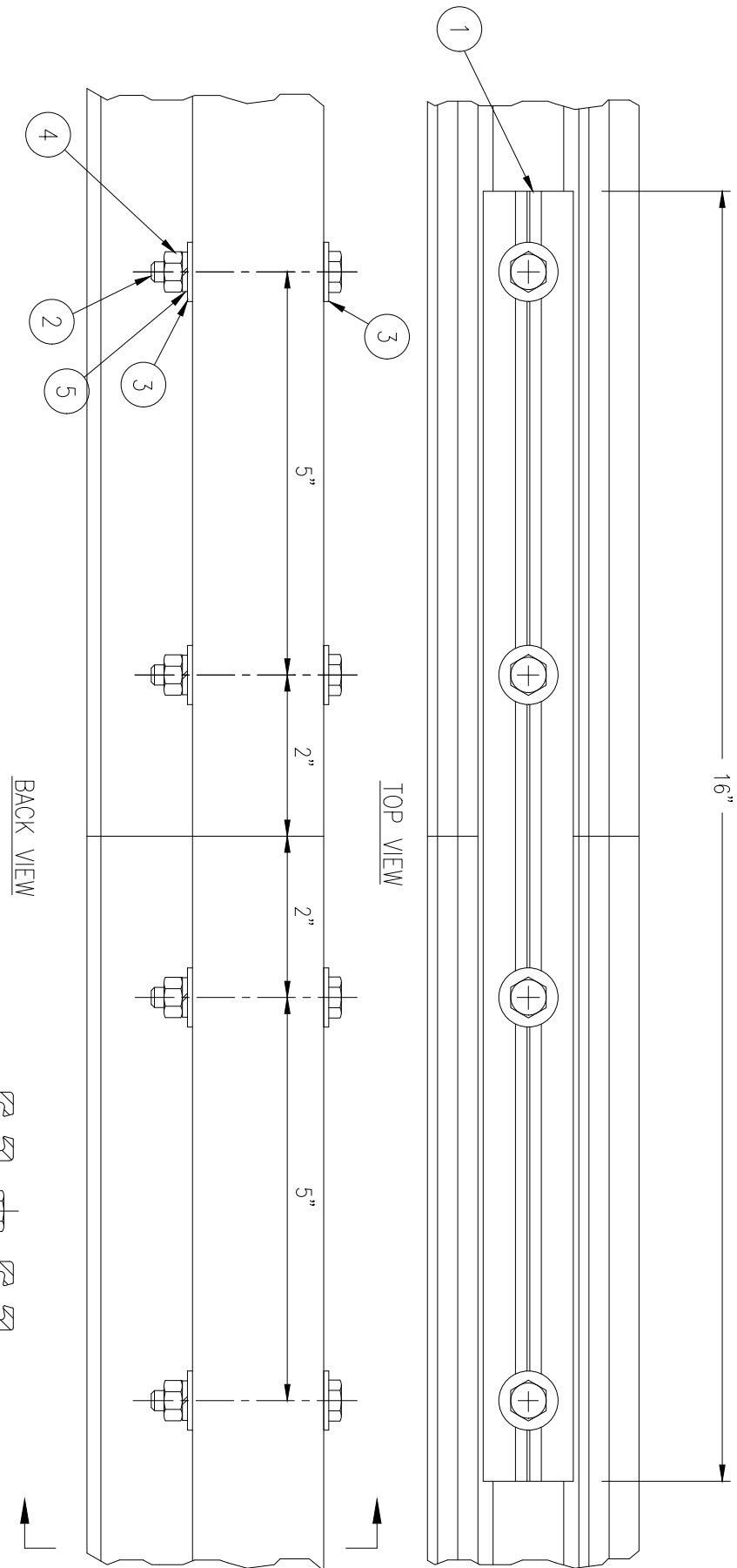

NOTE: MAXIMUM DISTANCE BETWEEN SPLICE IS 168"

1. Insert the **SPLICE (X FRAME)** completely into the end of one **RAIL**.



2. Line up the second rail and slide the **SPLICE (X FRAME)** so that it spans the joint between the two **RAILS**.

3. Using a 5/16" drill bit, drill 4 vertical holes through the **SPLICE (X FRAME)** and **RAILS**. Make sure there are 2 holes on each side of the **RAIL** joint.

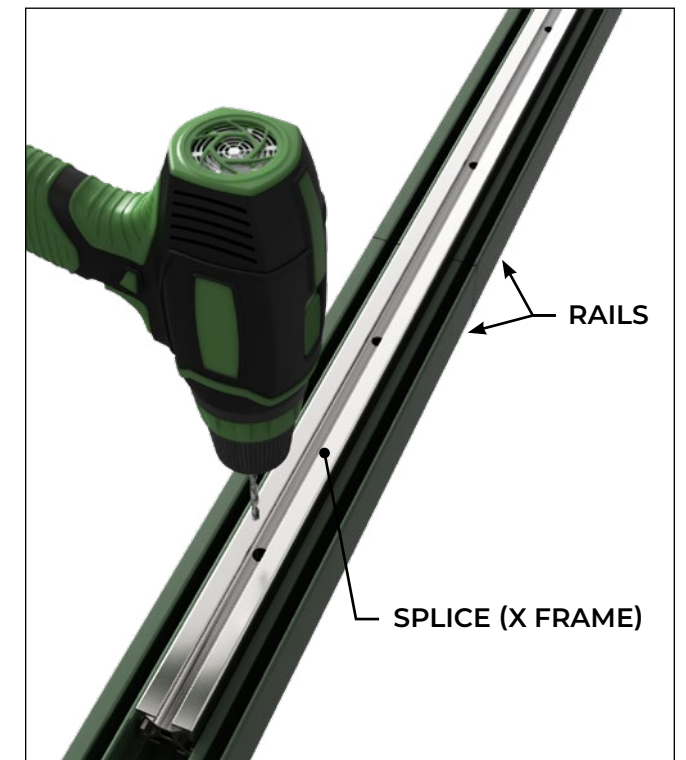
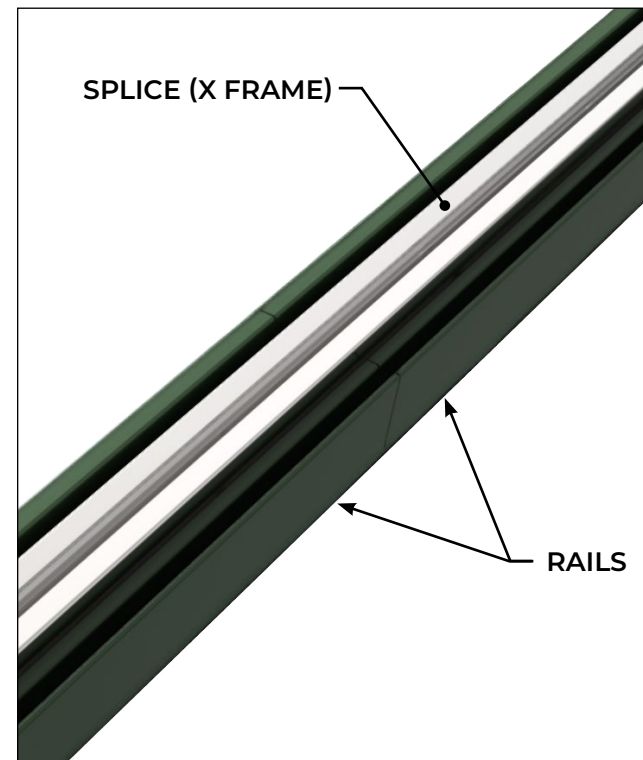

4. Secure the **SPLICE (X FRAME)** with a **2" HEX HEAD BOLT, FLAT WASHERS, LOCK WASHER** and **HEX NUT** in each through hole.

4.1. If **QUICK RELEASE PINS** are provided, insert them in place of the other fastening hardware mentioned above.

4.2. Refer to the *Job Specific Submittal Drawings* for location to be used.

STANDARD SPLICE

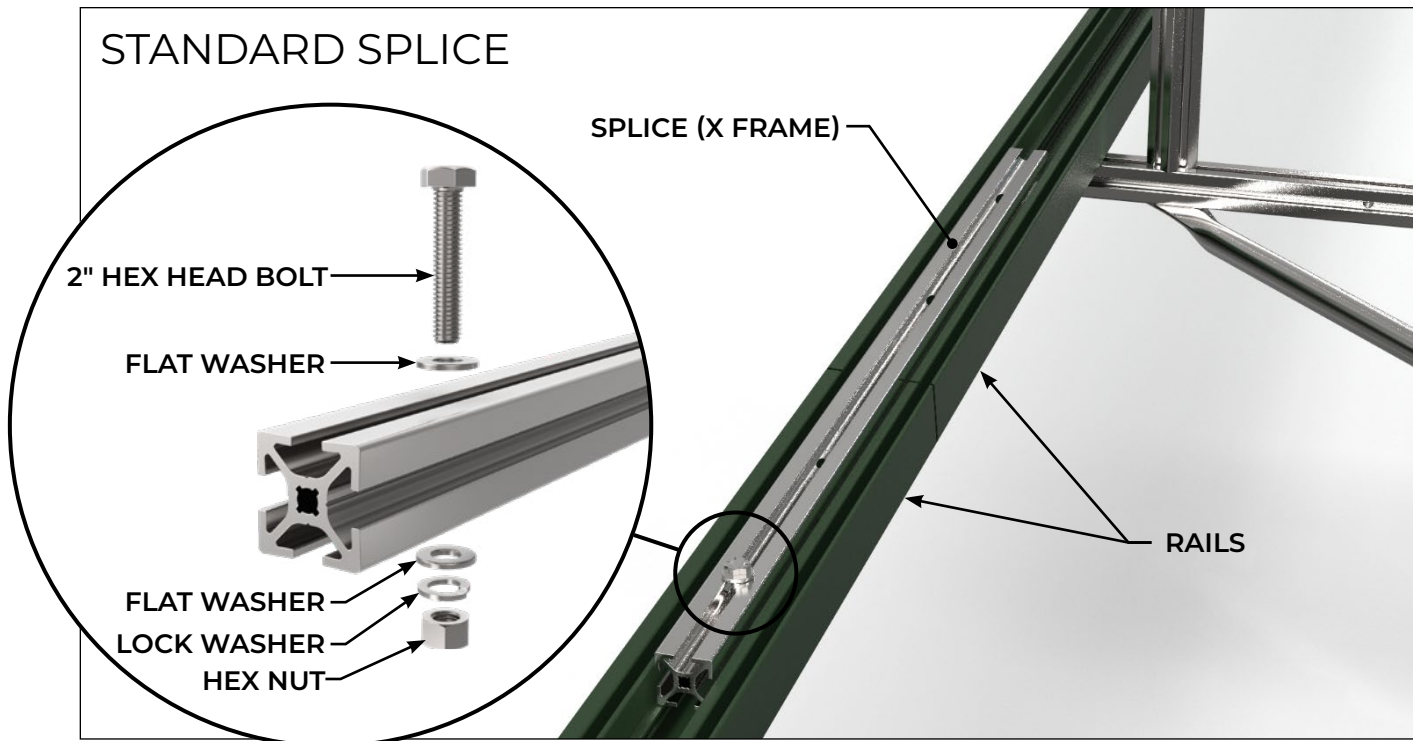

QUICK RELEASE SPLICE

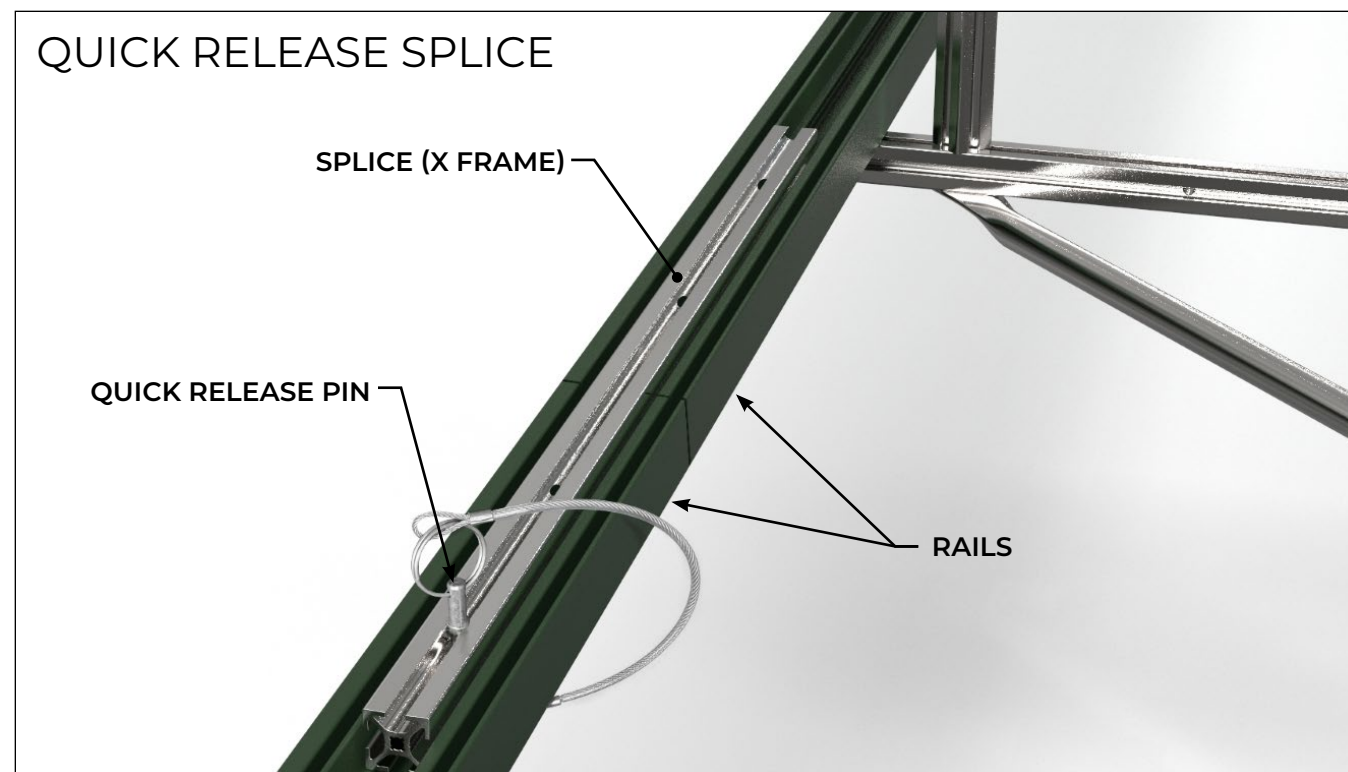

UNIT-ATTACHED INSTALL STEPS CONTINUED

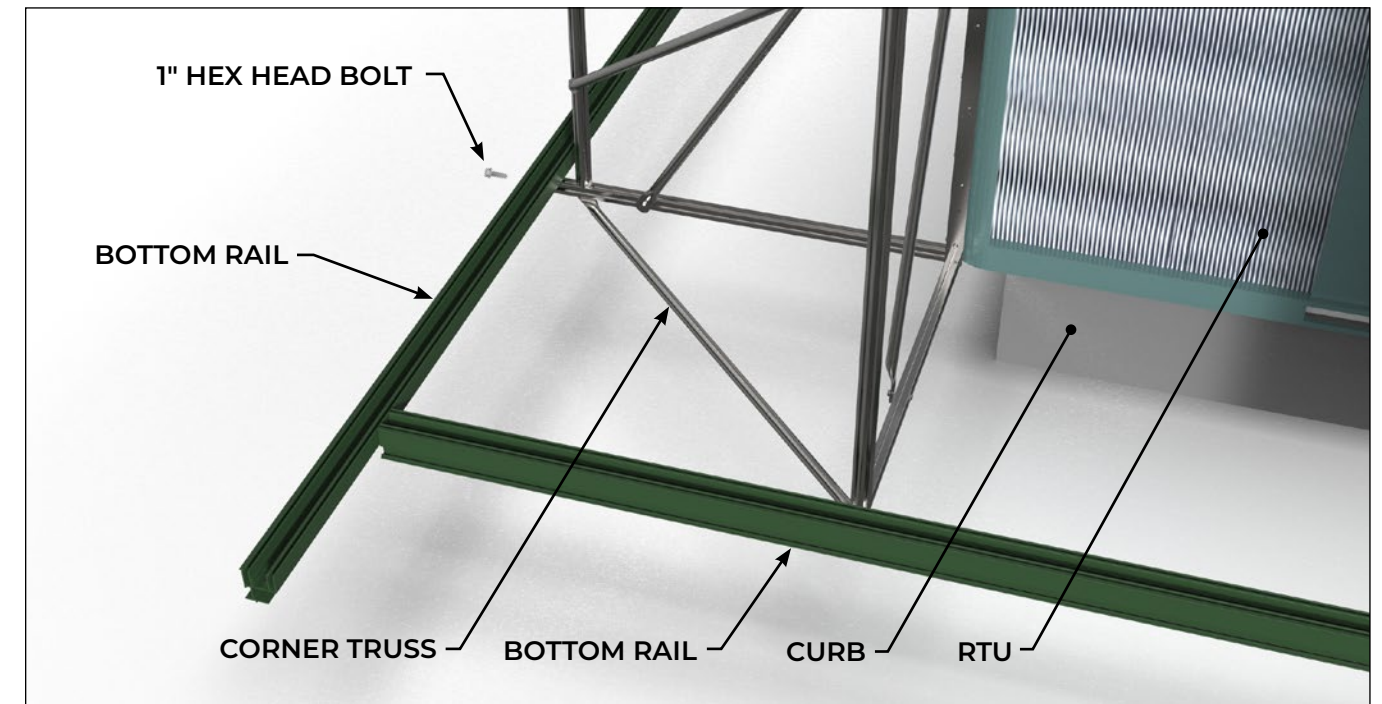

8. Starting at one corner of the RTU, position a **BOTTOM RAIL** against the installed **CORNER TRUSS**. Use a framing square to ensure the **BOTTOM RAIL** is flush and square with the **CORNER TRUSS**.

8.1. Mark the location of the clearance hole from the **CORNER TRUSS** extrusion onto the **BOTTOM RAIL** and drill a 5/16" hole.

8.2. Use a **1" HEX HEAD BOLT (SELF-TAPPING/TAPERED)**, fasten through **BOTTOM RAIL** into the **CORNER TRUSS** extrusion clearance hole.



9. Continue installing the **BOTTOM RAIL** at alternating legs of the **CORNER TRUSS** around the perimeter of the RTU.
 - 9.1. Make sure each **CORNER TRUSS** is square to the other **BOTTOM RAIL** before drilling and fastening.
 - 9.2. Install the remaining corners while checking the lengths of the **BOTTOM RAIL** on the opposing side of the RTU for equal distances.
10. Cut the **BOTTOM RAIL** to the inside face of the **BOTTOM RAIL**.

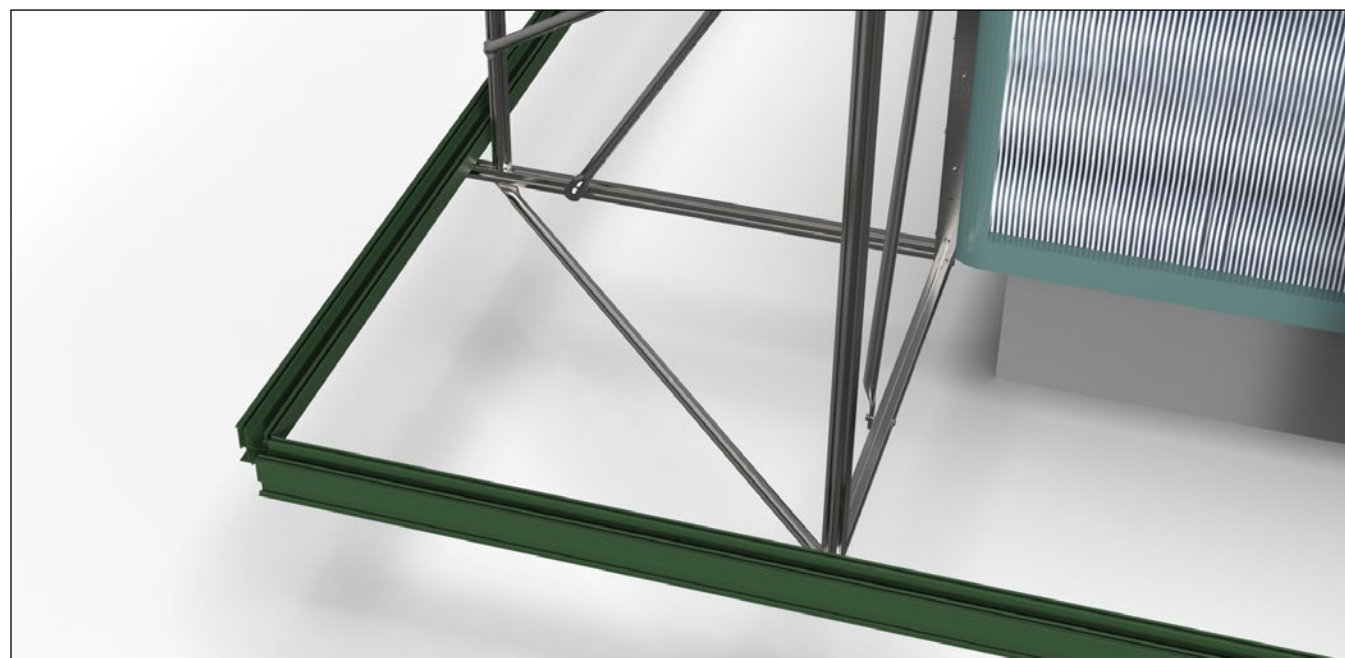
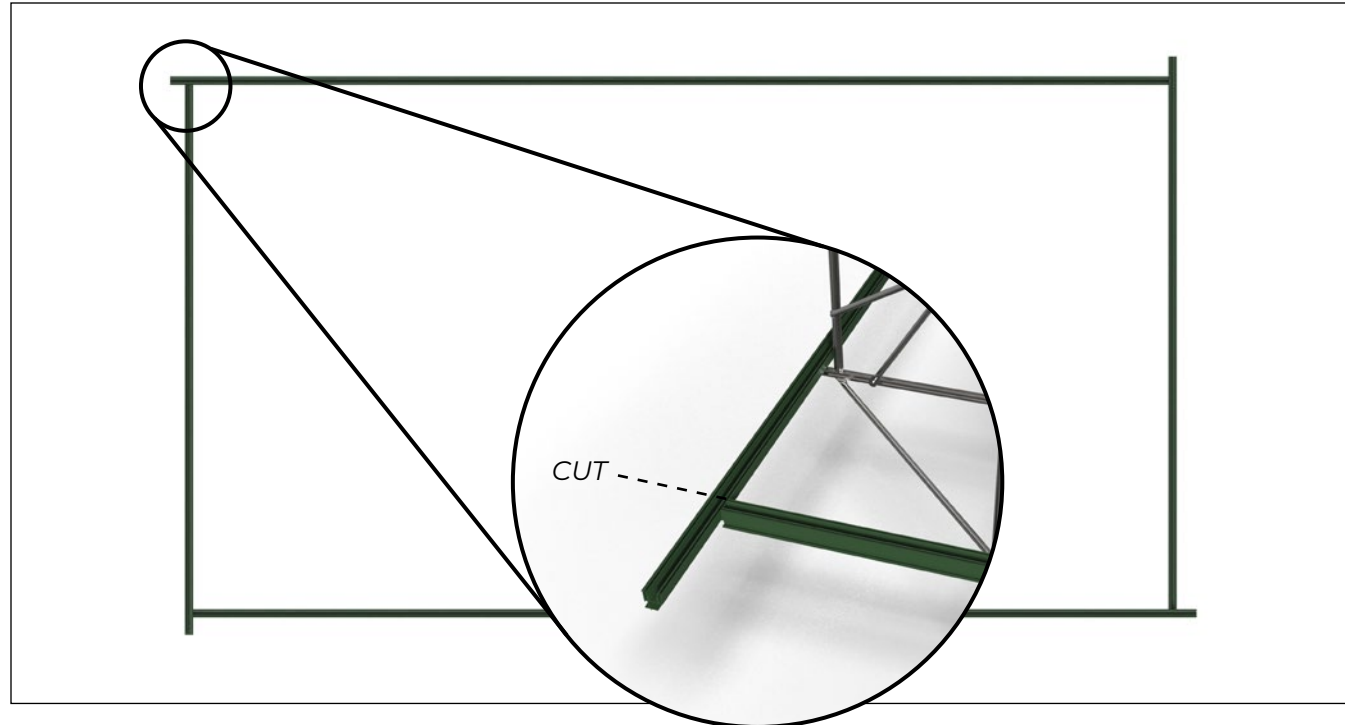

11. After all corners have been trimmed, insert the **BRACE RAIL** (approx. 6" length of **X FRAME** extrusion) into the "C" cavity of the **BOTTOM RAILS**. Pre-drill a pilot hole into the **BOTTOM RAILS** (through the top or bottom as needed) and secure the **BRACE RAIL** in place with **1 1/4" TEK SCREWS**.



If your Envisor® screening system is 4-sided, skip to page 31.

12. Place the casting end of the **STABILIZER BRACE** over the central slot along the side of the bottom leg of the **MIDSPAN TRUSS**. Slide the casting end until the opposite end of the **STABILIZER BRACE** (no end casting) is inside the "C" cavity of the **BOTTOM RAIL**.

Note: 4-sided Envisor® screening systems typically do not require STABILIZER BRACES; see your Job Specific Submittal Drawings to verify.

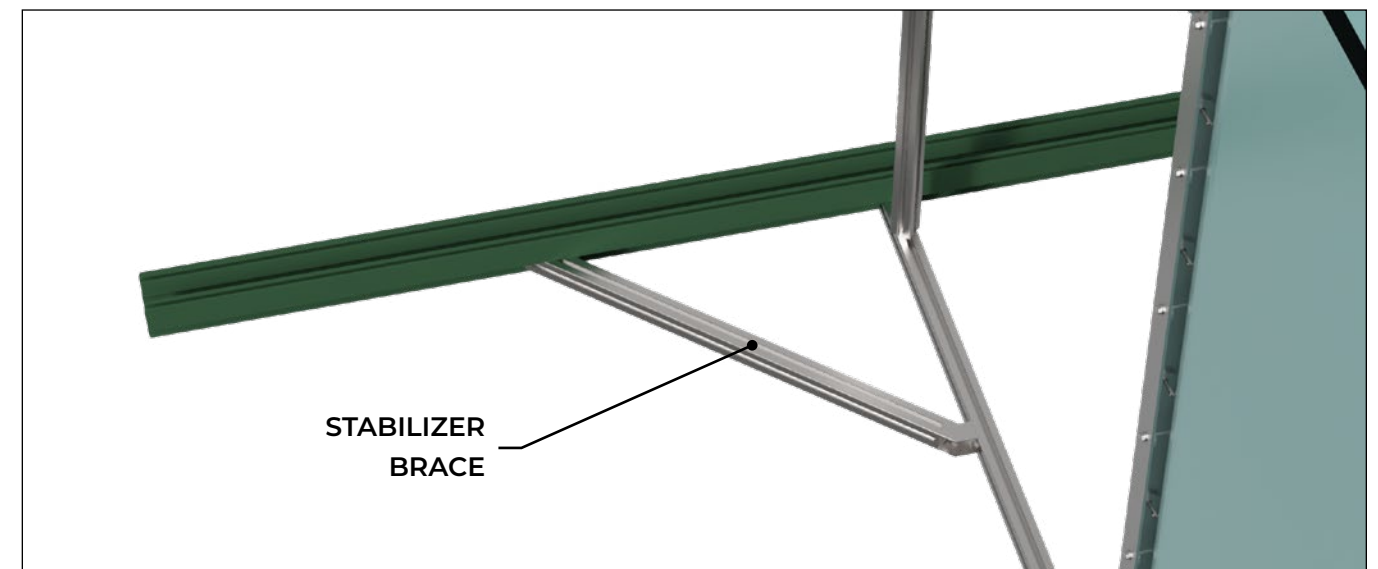

13. Drill a 5/16" hole through both the casting end of **STABILIZER BRACE** and bottom leg of **MIDSPAN TRUSS**, then attach the parts with **1 3/4" HEX HEAD BOLT, FLAT WASHER** and **NYLOCK NUT**, using the drilled hole as a guide.
14. Attach the other end of the **STABILIZER BRACE** to the **BOTTOM RAIL** using a **1 1/4" TEK SCREW** (drill first through the bottom of the bottom rail's mounting slot.)

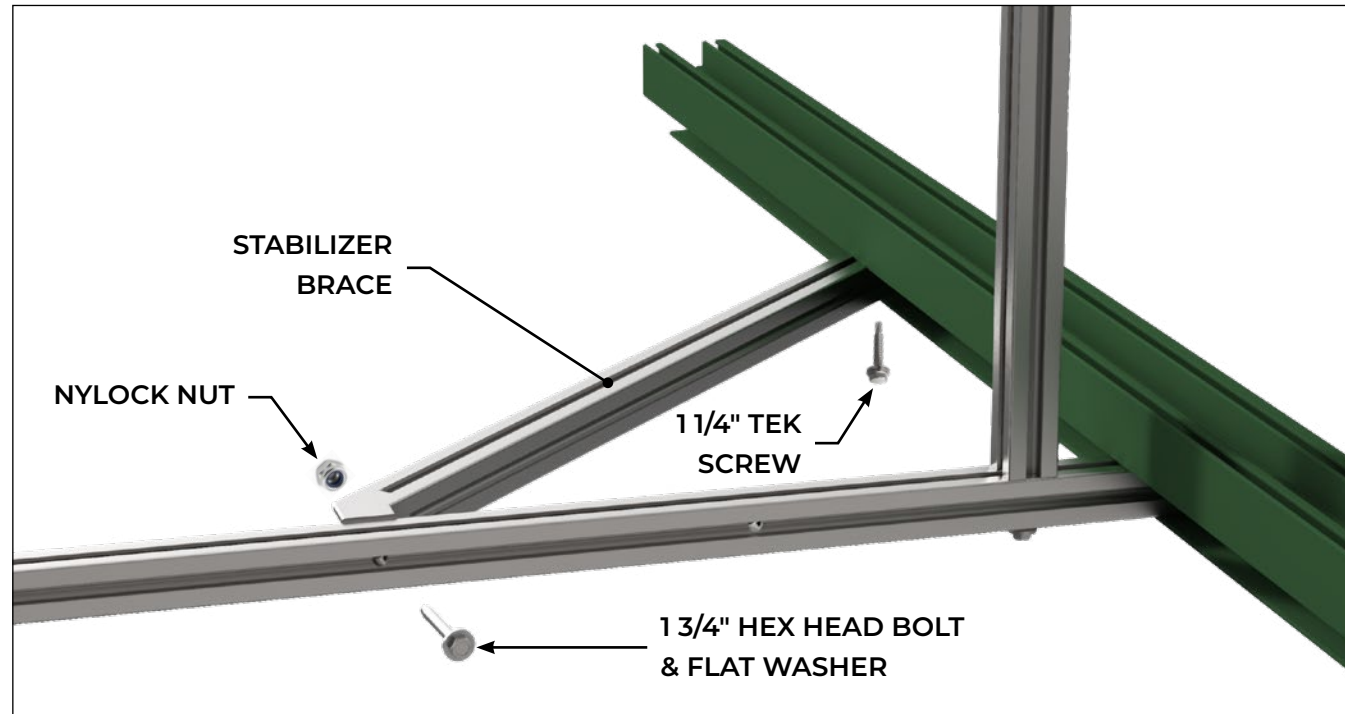

15. Repeat steps 8-14 for **TOP RAIL** and other open side of screen.

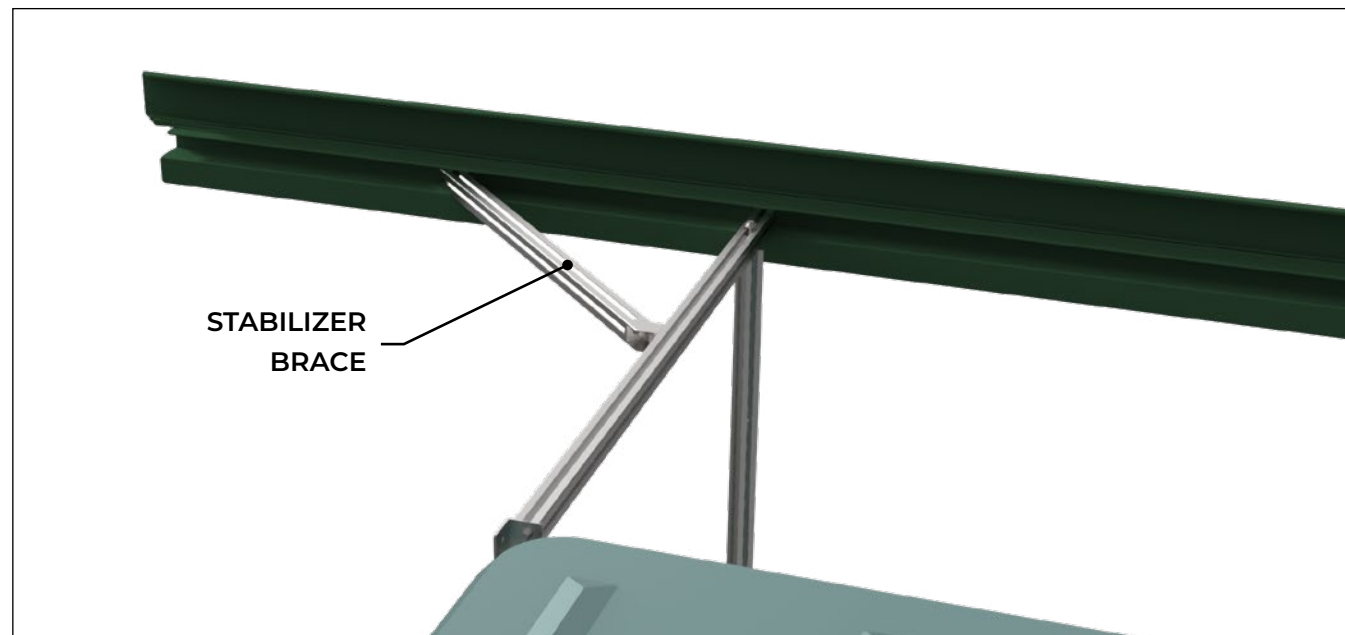

Before continuing, check the **Job Specific Submittal Packet** and **Packing List**. Follow the matching kit instructions below:

- **TOP TRIM ASSEMBLY – Lineal Band, 2-Step, & 3-Step**, go to page **32**
- **TOP TRIM ASSEMBLY – Alamo & Cove**, go to page **36**
- **BOTTOM TRIM ASSEMBLY**, go to page **38**
- **STACKED SYSTEM INSTALL STEPS**, go to page **40**
- **GAP BRACE INSTALL STEPS**, go to page **41**
- **ALTERNATE POST SUPPORTS**, go to page **43**

After completing the steps above (or if none apply), continue with the main **UNIT-ATTACHED INSTALL STEPS** on page **50**.

TOP TRIM ASSEMBLY

LINEAL BAND, 2-STEP, & 3-STEP

The **TOP TRIM** is fabricated from aluminum components and attaches to the **TOP RAIL** with **3/4" TEK screws**.



3" Lineal Band



2-Step



3-Step

1. Layout the **TOP TRIM** pieces on the ground to ensure you have the correct lengths for each side of the Envisor® screen.
2. While pieces are on the ground, join a mitered corner by connecting a **LEFT TOP TRIM** piece to a **RIGHT TOP TRIM** using the **CORNER TABS** and **CORNER KEYS**.
 - 2.1. Insert the **CORNER KEY** into the horizontal channel located on the back of the **TOP TRIM**.
 - 2.2. Secure the **CORNER KEY** to the right **TOP TRIM** piece using the flat head screws that are already set into the **CORNER KEY**.

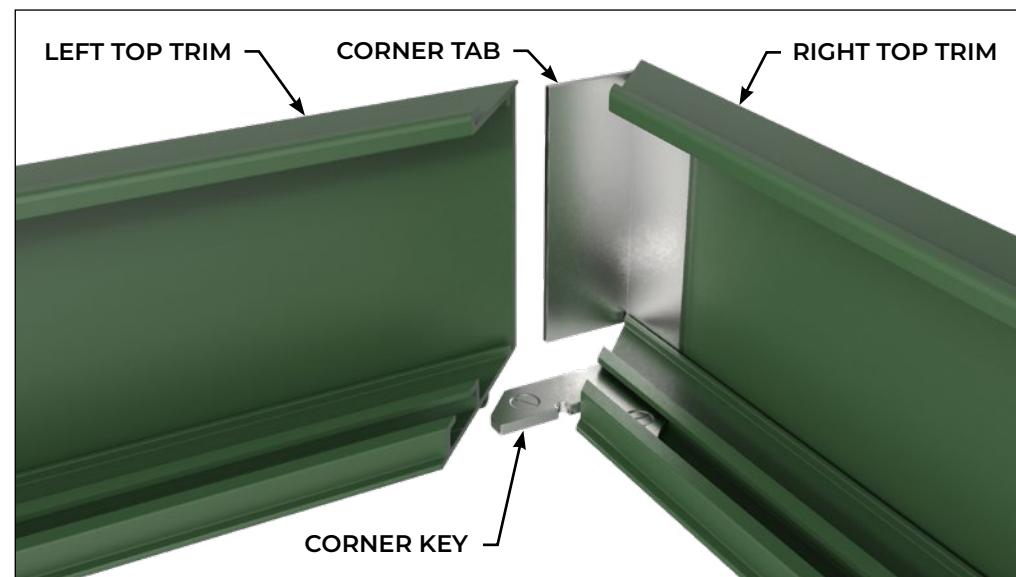

- 2.3. Install the **CORNER TAB** in the vertical channel of the **RIGHT TOP TRIM**, with the point of the angle at the edge of the piece.
- 2.4. Connect to the **LEFT TOP TRIM** and secure with flat head screw already in **CORNER KEY**.

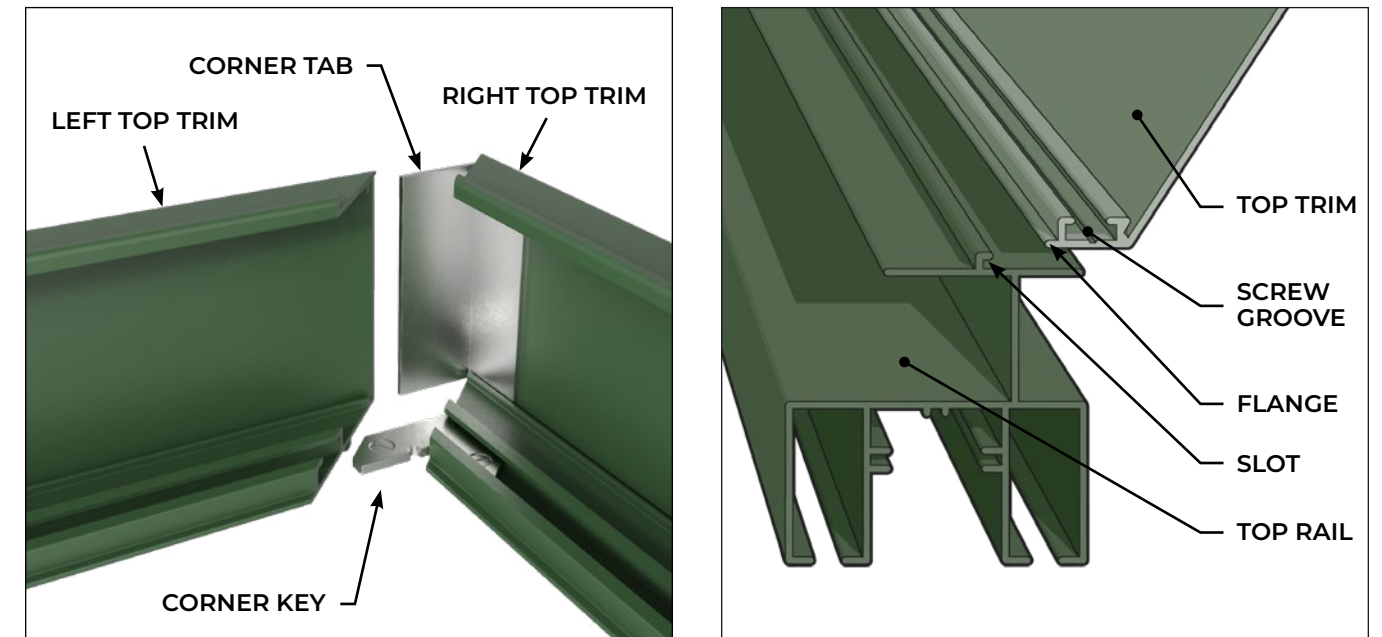

3. Lift the mitered assembled corner and insert the flange into the slot along the top of the **TOP RAILS**. Secure with several **3/4" TEK SCREWS** every 12" through the screw groove. *The screws will be visible from the outside.*
4. Measure the distance from this installed piece to the next corner.

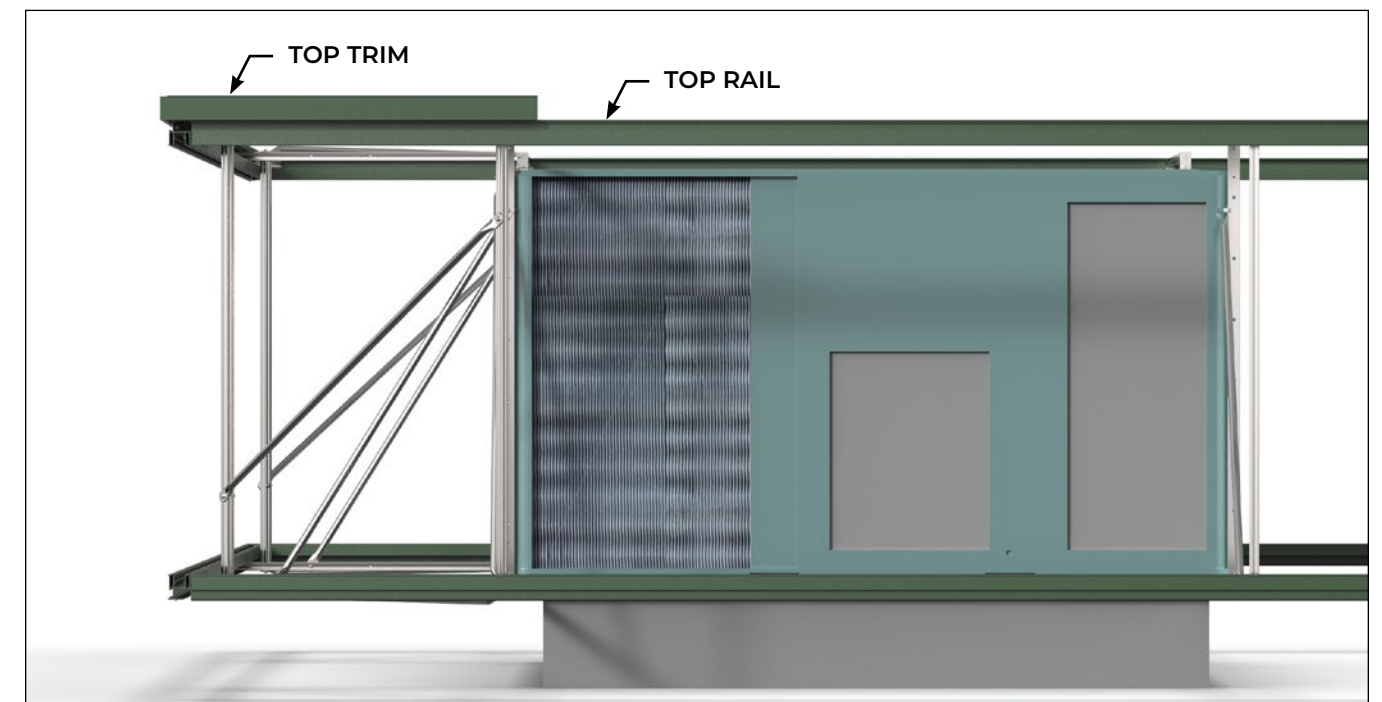

5. Cut a piece of **TOP TRIM** on the straight end to this measurement.

⚠️ 5.1. Do not cut the mitered end. Cuts must be located at least 24" from the mitered corners.

5.2. Save any trimmed (drop) pieces to use on other sides to fill gaps between **TOP TRIM** mitered pieces.

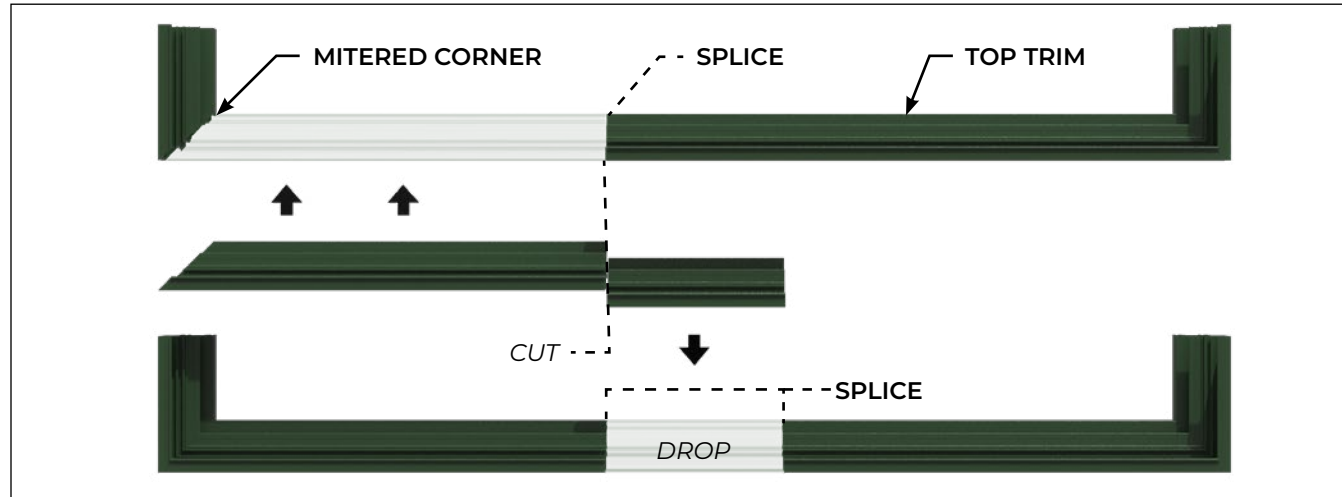

6. Use the **SPLICE KEYS** and **SPLICE PLATES** to connect these pieces.

6.1. Insert the **SPLICE KEY** into the horizontal channel located on the back of the **TOP TRIM**.

6.2. Secure the **SPLICE KEY** to each **TOP TRIM** piece with **3/4" TEK SCREWS**.

6.3. Insert the **SPLICE PLATE** into the vertical channels.

6.4. Make sure the **SPLICE KEY** and **SPLICE PLATE** overhang the cut end of the **TOP TRIM**.

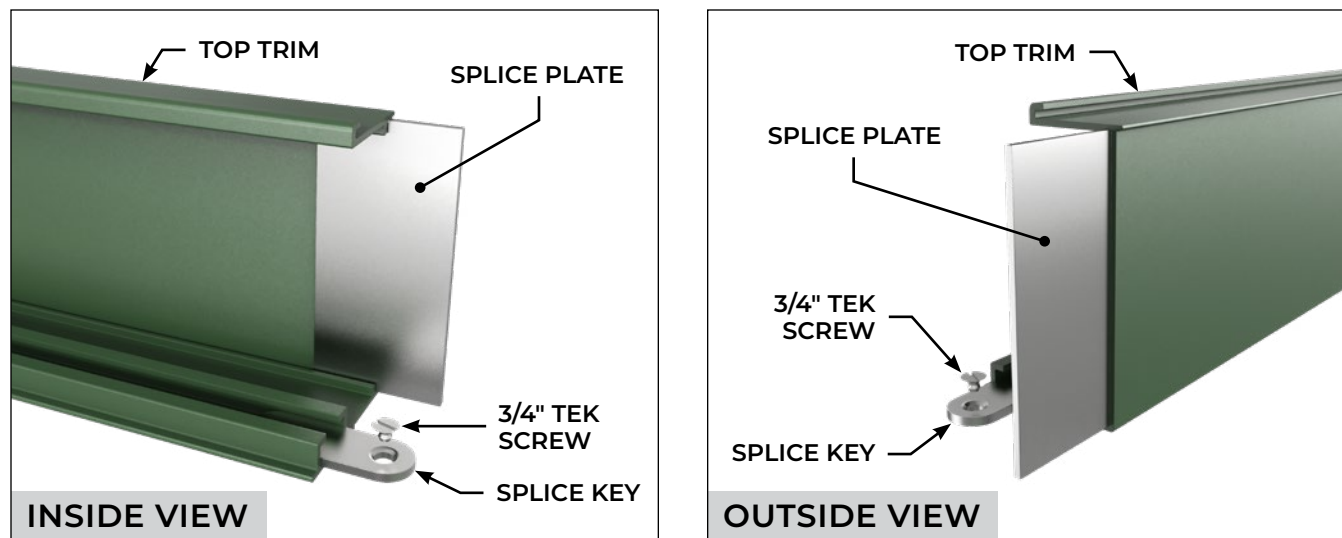

Quick Tip: Use an oil-based lubricant as needed to help assemble.

7. Attach the cut piece to the corner that is already installed on the **TOP RAIL**.

7.1. Line up the **SPLICES** with the screw grooves on the previously installed piece and slide into place.

7.2. Secure the **SPLICE KEYS** with two **3/4" TEK SCREWS** through the screw groove of the **TOP RAILS**.

8. If needed, add additional **3/4" TEK SCREWS** every 12".

9. Repeat steps **4-8** for the remaining corners.

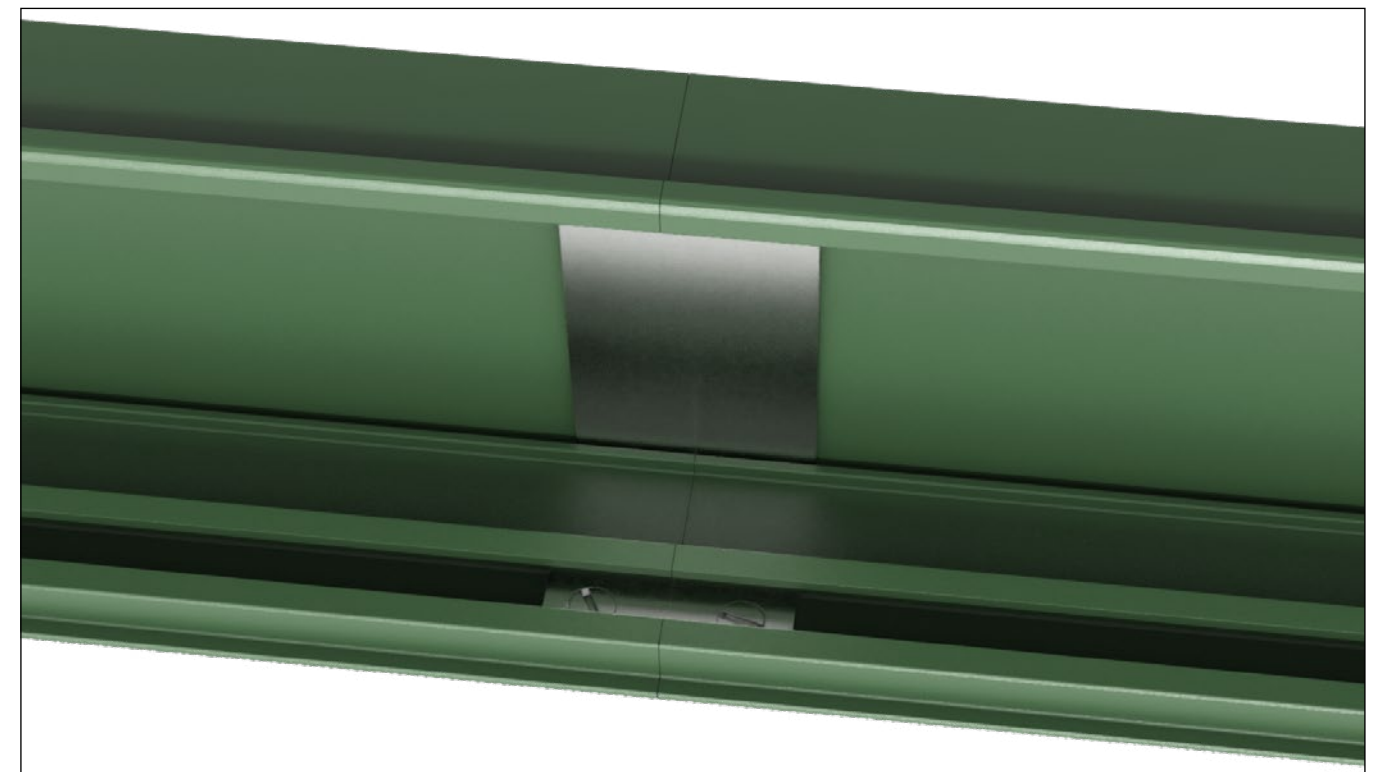

TOP TRIM ASSEMBLY

ALAMO & COVE

The **TOP TRIM** is fabricated from aluminum components and attaches to the **TOP RAIL** with **3/4" TEK SCREWS**.

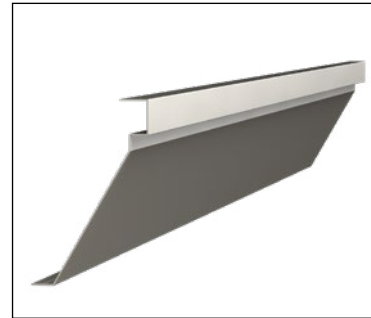

Alamo

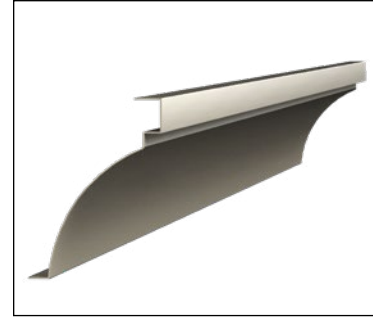

Cove

1. Position the **CORNER PIECE TOP TRIM** at each corner as required by the **Job Specific Submittal Drawings** and attach them to the **TOP RAIL** with **3/4" TEK SCREWS**. Measure the distance between the two **CORNER PIECE TOP TRIMS** before cutting the straight section of **TOP TRIM**.

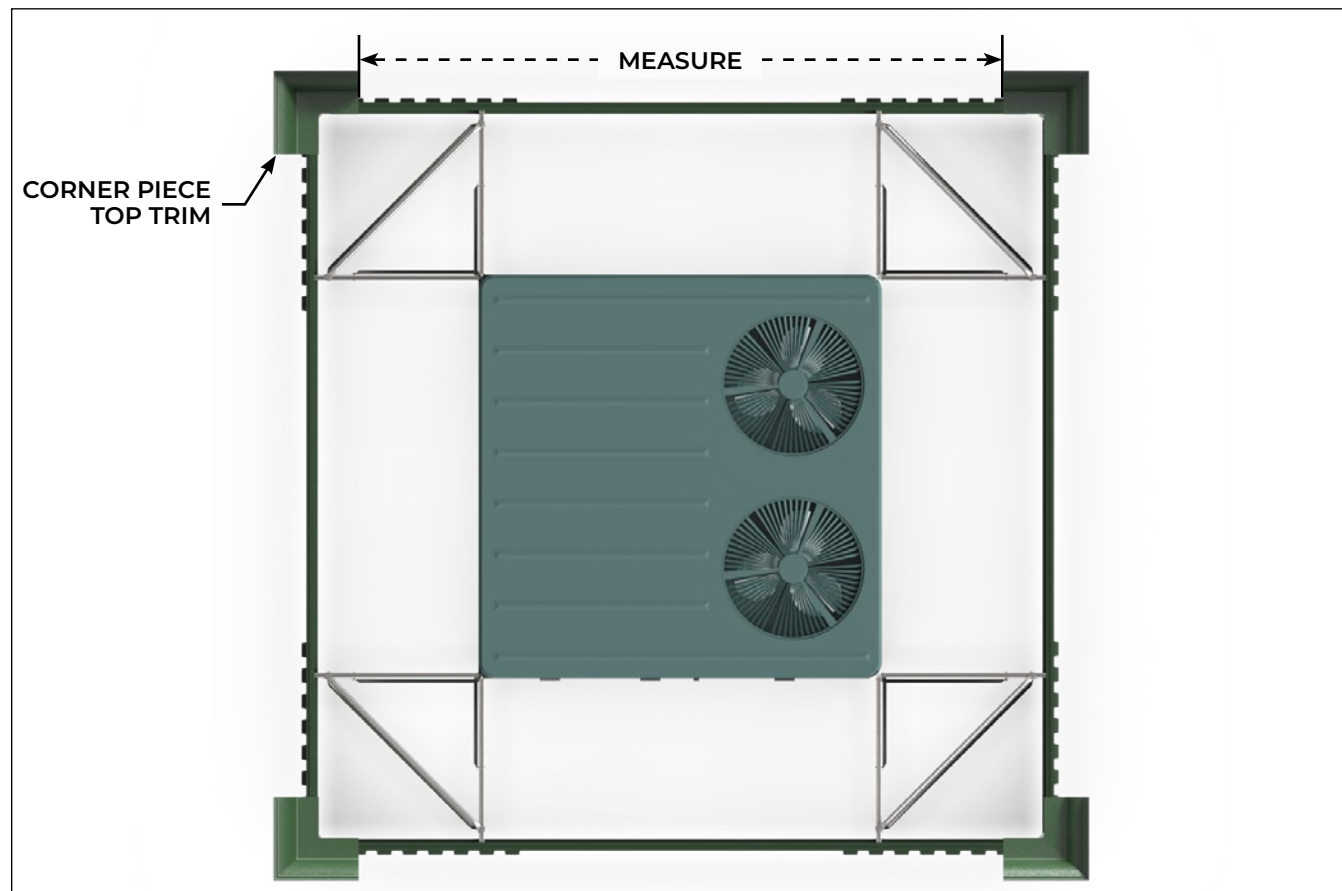

2. Join the straight section **TOP TRIM** with the **CORNER PIECE TOP TRIM** using the **(TOP) SPLICE KEY**, **(BOTTOM) SPLICE KEY** and **SPLICE PLATE**. Secure the **TOP KEY** and **BOTTOM KEY** with **3/4" TEK SCREWS**.
3. Repeat steps 1 and 2 on all remaining sides.

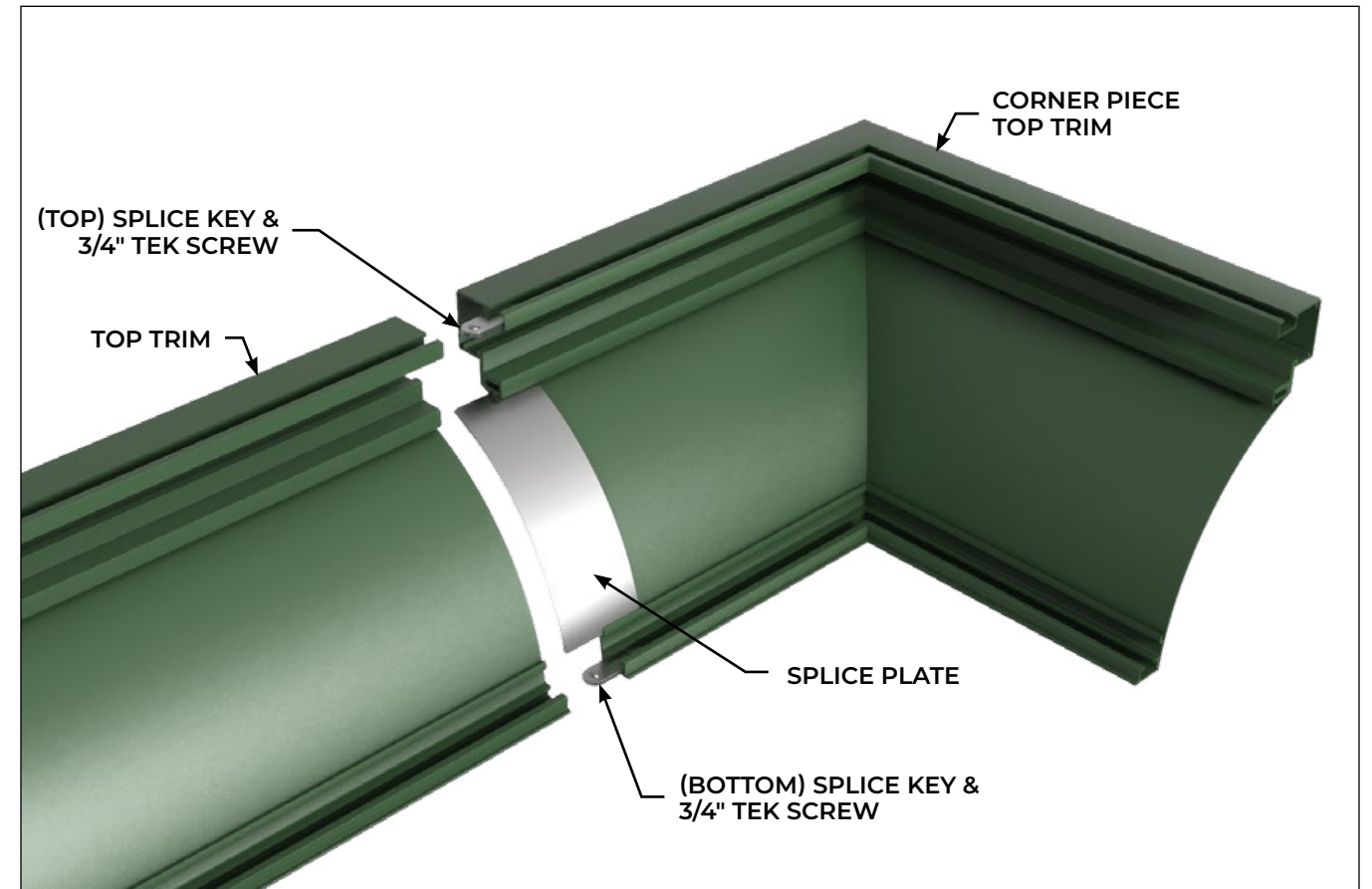

BOTTOM TRIM ASSEMBLY

The **BOTTOM TRIM** is fabricated from aluminum components and attaches to the **BOTTOM RAIL** with **3/4" TEK SCREWS**.

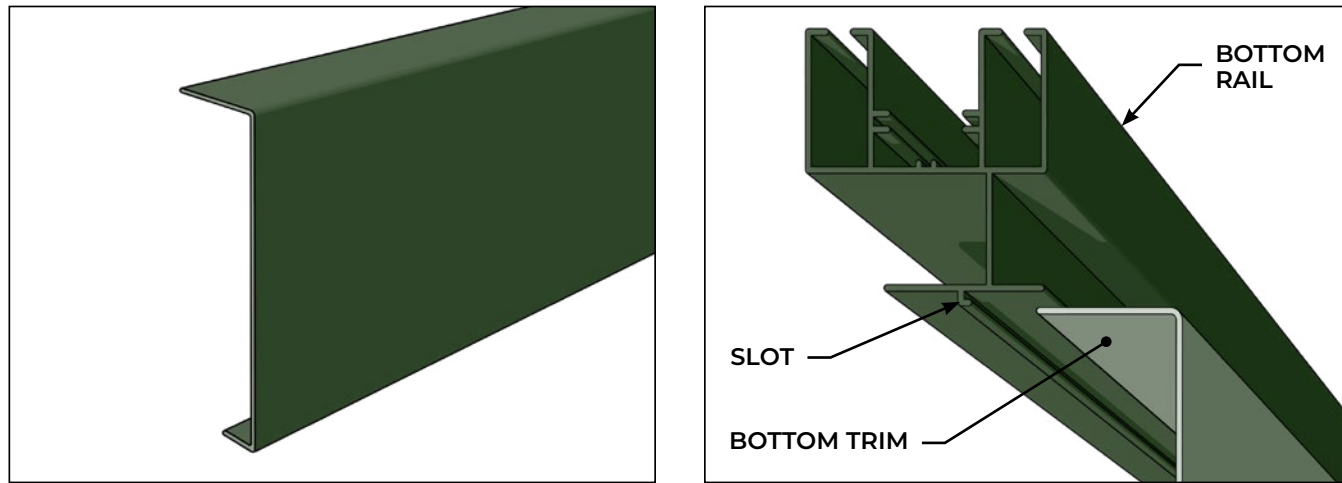

1. Layout the **BOTTOM TRIM** pieces on the ground to ensure you have the correct lengths for each side of the Envisor® screen.
 - 1.1. Consult the **Job Specific Submittal Drawings** for trim type, and cut mitered ends at corner as needed.
 - 1.2. Pre-fit the **BOTTOM TRIM** pieces together on the ground at one corner.
2. Insert the flange of one these **BOTTOM TRIM** piece into the small slot on the bottom of the **BOTTOM RAIL**, leaving enough overhang to form a clean corner.
3. Secure the **BOTTOM TRIM** to the **BOTTOM RAIL** with **3/4" TEK SCREWS** every 12" as needed.

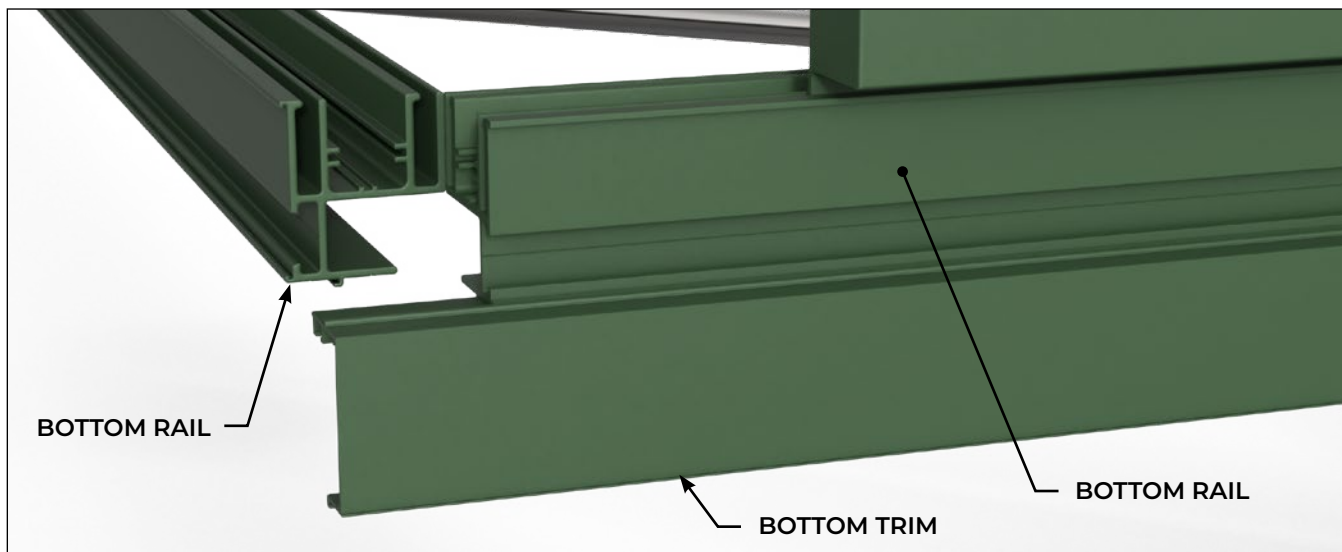

4. Measure the distance from this installed piece to the next corner.
5. Cut a piece of **BOTTOM TRIM** to this measurement. Save any trimmed (drop) pieces to use on other sides to fill gaps between **BOTTOM TRIM** pieces.
6. Line up this cut **BOTTOM TRIM** piece with the piece already attached to the **BOTTOM RAIL**.
7. Connect the two **BOTTOM TRIM** pieces.
 - 7.1. Place a **SPLICE PLATE** across the back of the cut ends of the **BOTTOM TRIMS**.
 - 7.2. Secure the **SPLICE PLATE** to the **BOTTOM TRIMS** using **3/4" TEK SCREWS** inserted from the outside of each **BOTTOM TRIM** into the **SPLICE PLATE**.
8. Secure the second **BOTTOM TRIM** piece to the **BOTTOM RAIL** with **3/4" TEK SCREWS** every 12" as needed.
9. Line up the next side **BOTTOM TRIM** so it meets the already installed **BOTTOM TRIM** at the corner. Secure at the corner with a **CORNER TAB** and **3/4" TEK SCREWS**.
10. Repeat steps 4-9 for the remaining corners.

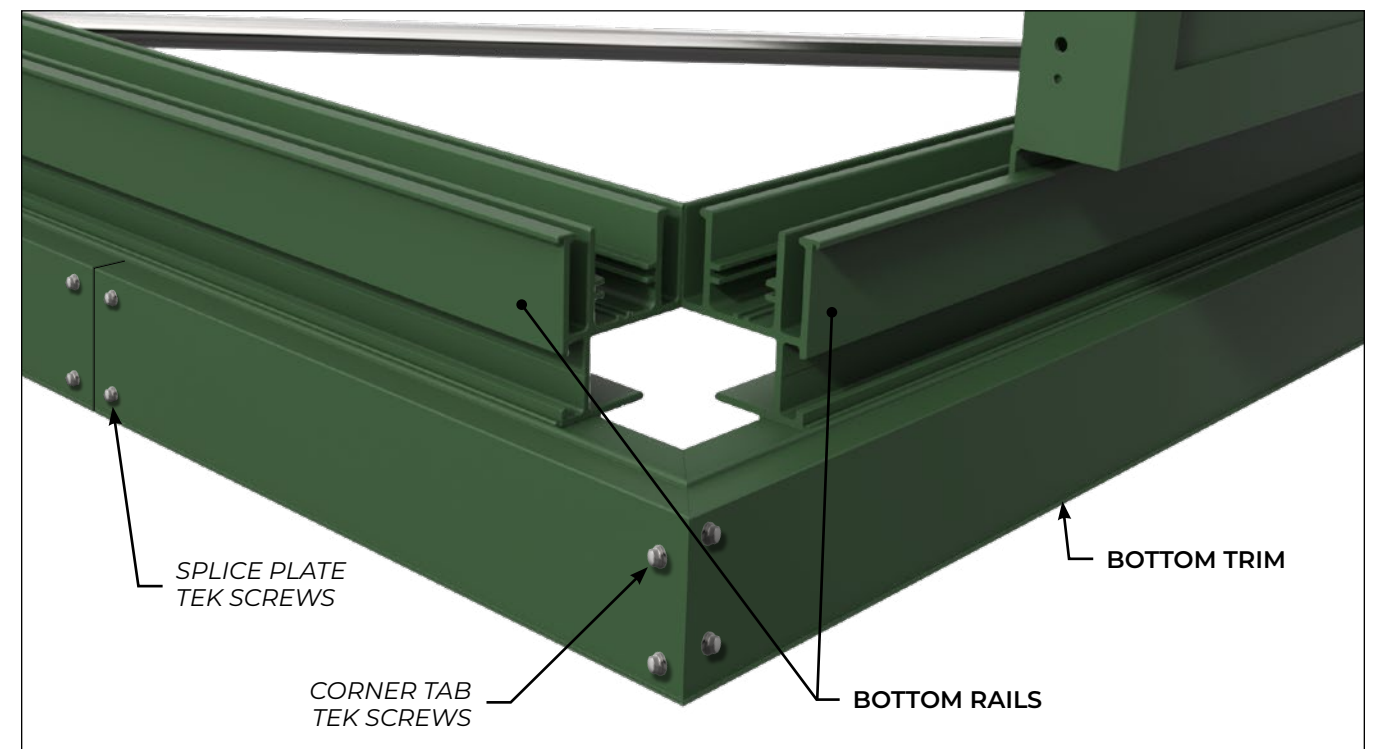

STACKED SYSTEM INSTALL STEPS

When installing a stacked screen, follow the **Installation Instructions** starting with the top screen. When installing the bottom screen, the gap between the top truss and bottom truss should be 2".

Note: Always reference the Job Specific Submittal Drawings for placement of trusses and Job Specific Parts.

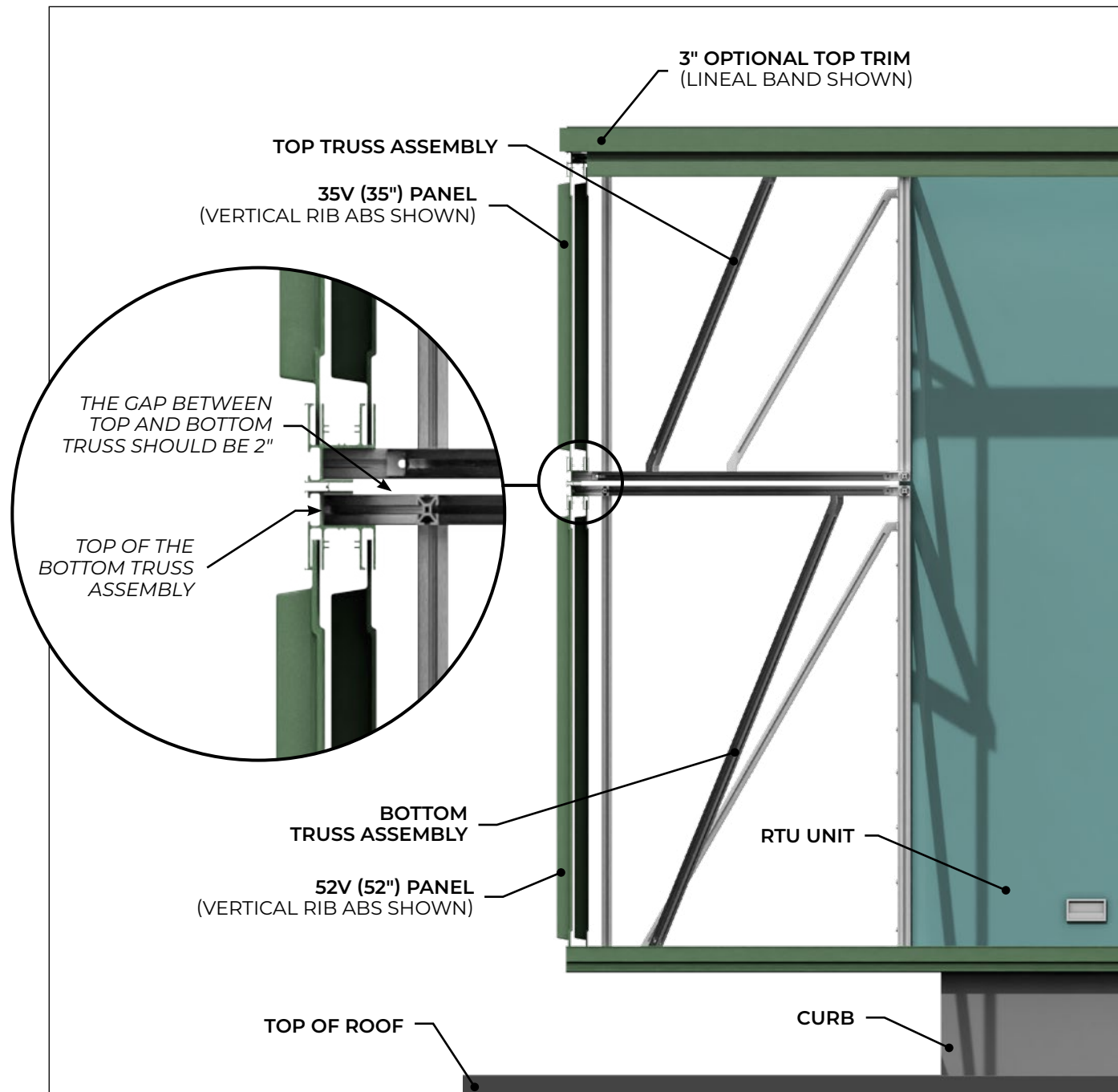

GAP BRACE INSTALL STEPS

Note: Always reference the Job Specific Submittal Drawings for placement of trusses and Job Specific Parts.

GAP BRACE PARTS:

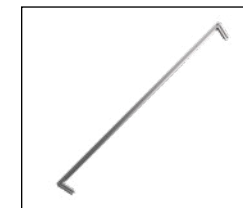

Aluminum Angle

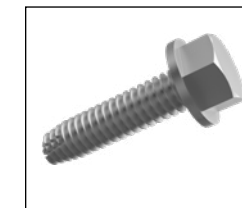

1" Hex Head Bolts (self-tapping/tapered)



3.5" X Frame

1. Connect one of the horizontal **X FRAME** pieces to each end of the **ALUMINUM ANGLE** using the **1" HEX HEAD BOLTS**.

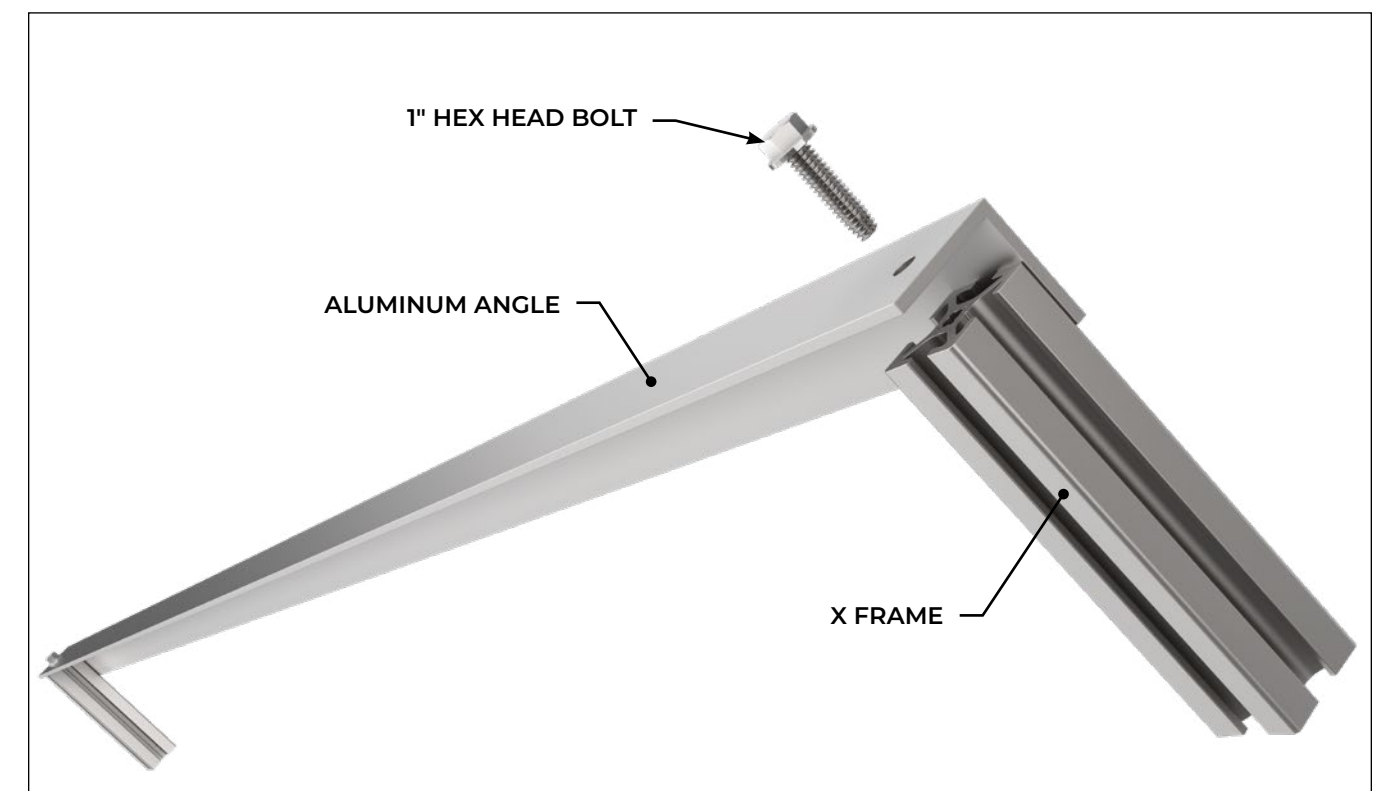

2. Mark the location of the pilot hole from the **X FRAME** extrusion onto the **BOTTOM RAIL** and **TOP RAIL** and drill a 5/16" hole.
3. Fasten 1" **HEX HEAD BOLTS** through **BOTTOM RAIL** and **TOP RAIL** into the **X FRAME** pilot hole.

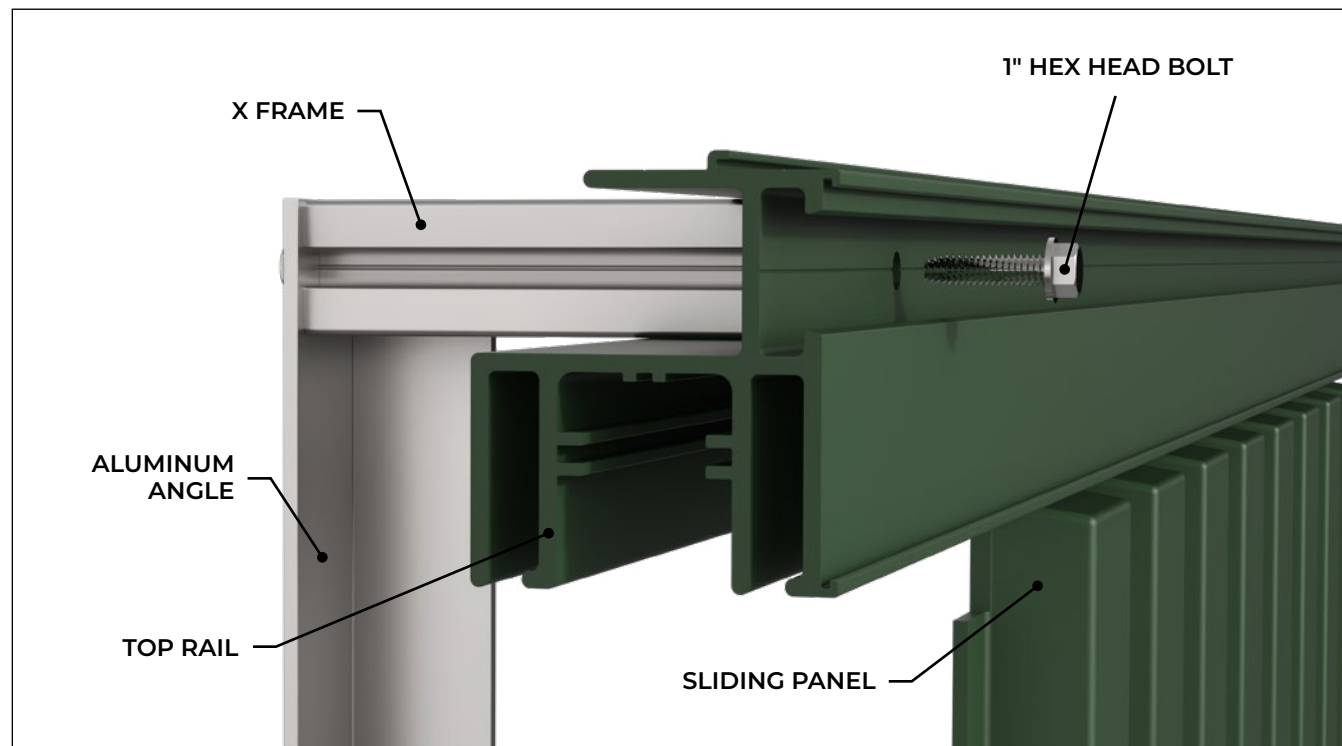
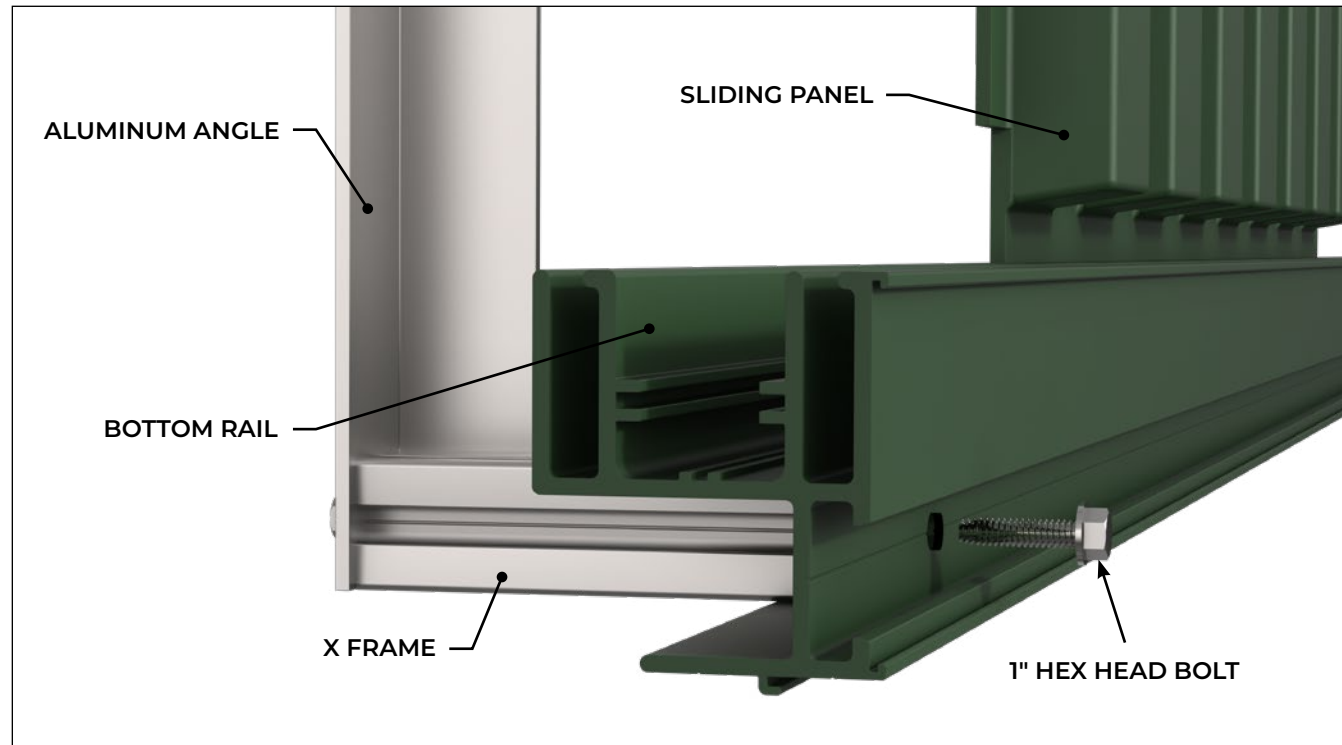

ALTERNATE POST SUPPORT INSTALL STEPS

Note: Always reference the Job Specific Submittal Drawings for placement of trusses and Job Specific Parts.

ALTERNATE POST SUPPORT PARTS:



SINGLE FOOT:

1. Referring to the **Job Specific Submittal Drawings**, place the **RUBBER STUD PAD** on the roof membrane at its intended location.
2. Place the **FOOT** on top of the **RUBBER STUD PAD**.

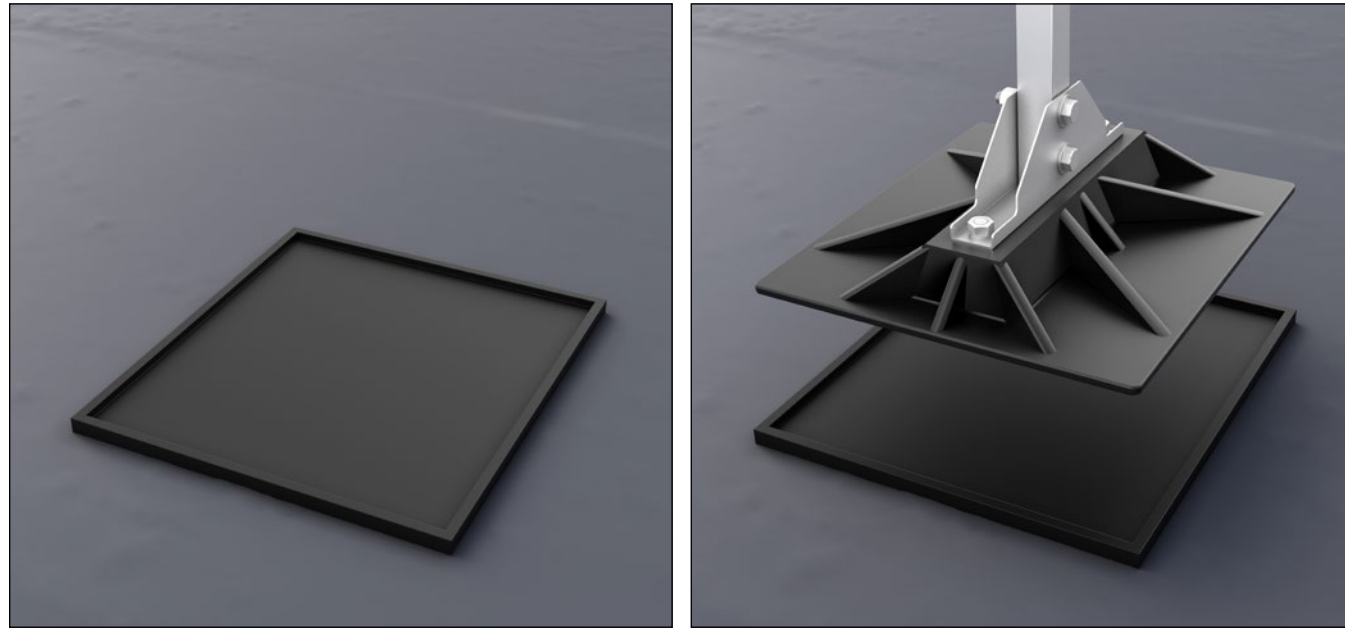

3. Insert the **UPRIGHT SUPPORT TUBE** into the **FOOT** and secure together (top & bottom holes) with **2" HEX HEAD BOLT**, **(2) FLAT WASHERS**, **LOCK WASHER**, and **HEX NUT**.

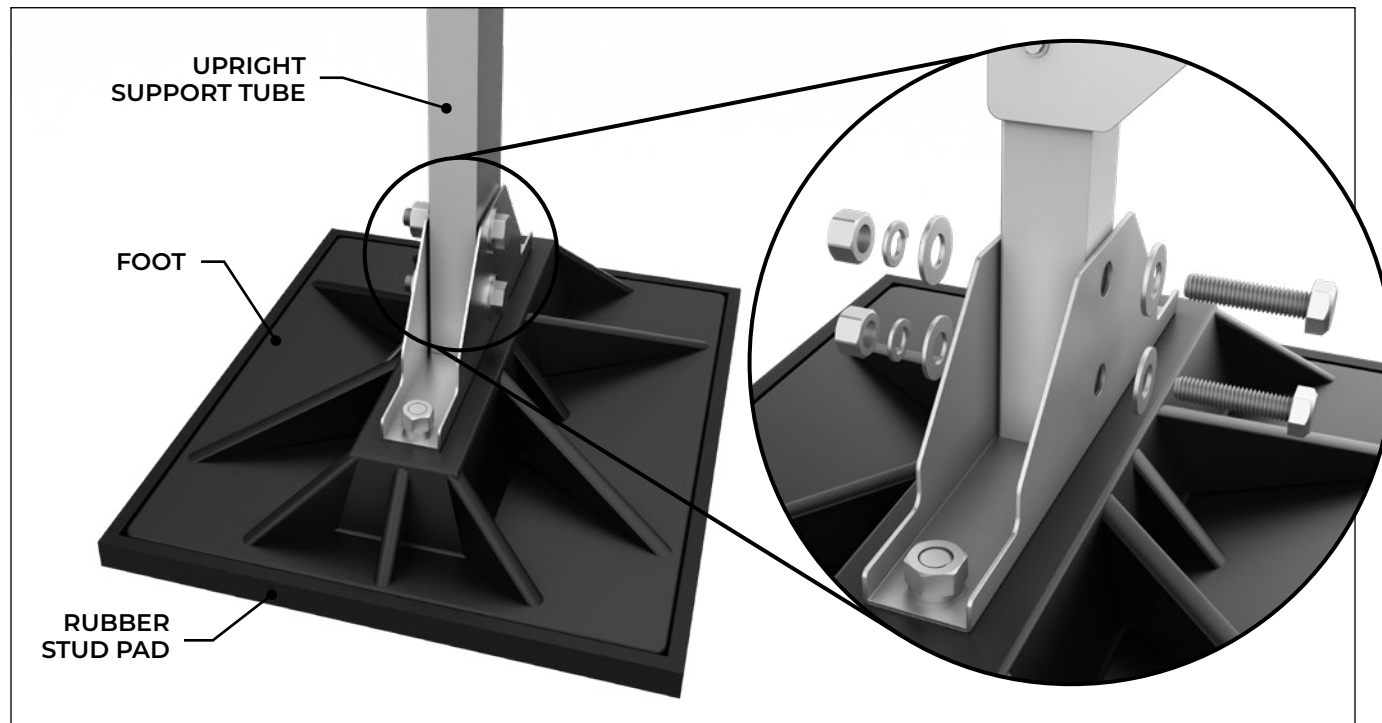

4. Drill $17/32$ " holes and attach the **ANGLE BRACKETS** to the **UPRIGHT SUPPORT TUBE** using the **4" HEX HEAD BOLT**, **(2) FLAT WASHERS**, **LOCK WASHER**, and **HEX NUT**. Confirm **ANGLE BRACKETS** orientation prior to tightening completely.

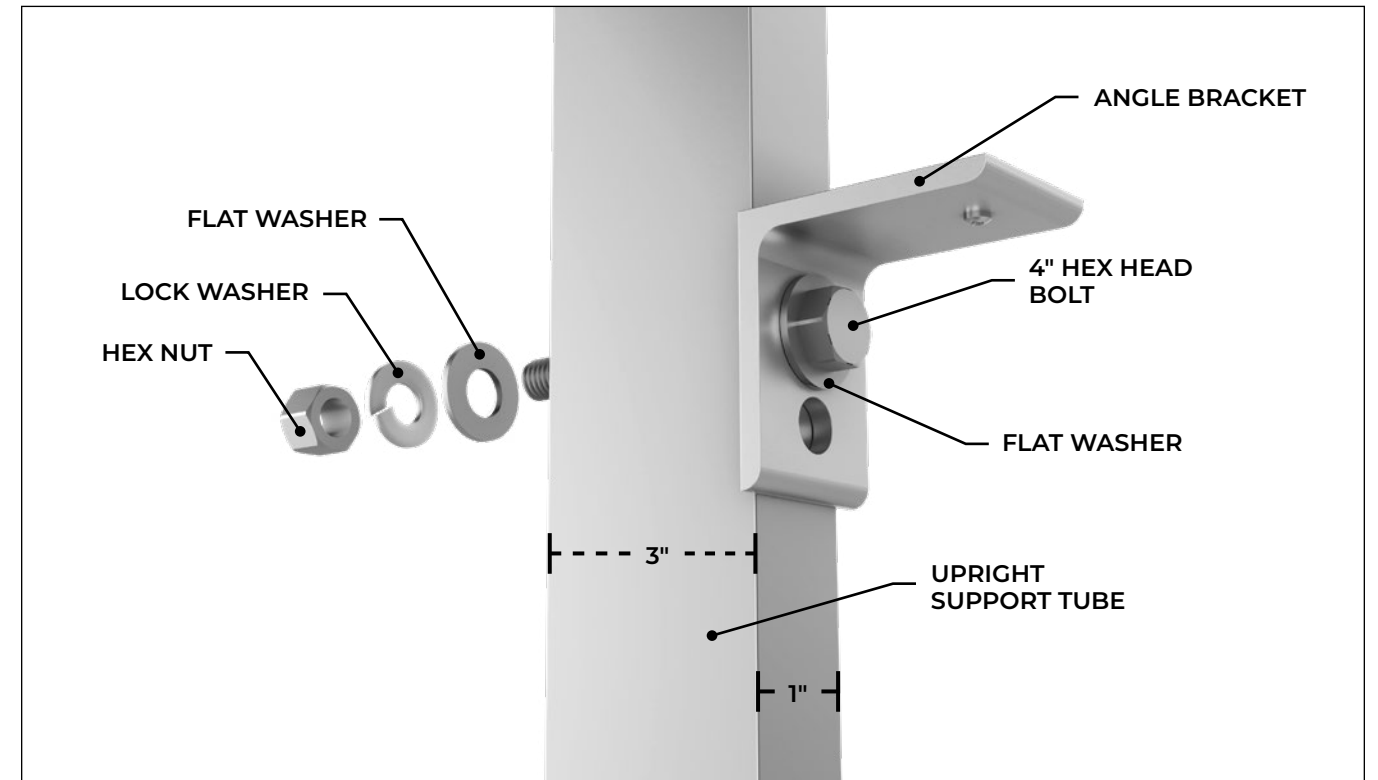

DOUBLE FOOT:

1. Referring to the **Job Specific Submittal Drawings**, place the **RUBBER STUD PADS** on the roof membrane at their intended locations.
2. Place each **FOOT** on top of the **RUBBER STUD PADS**.

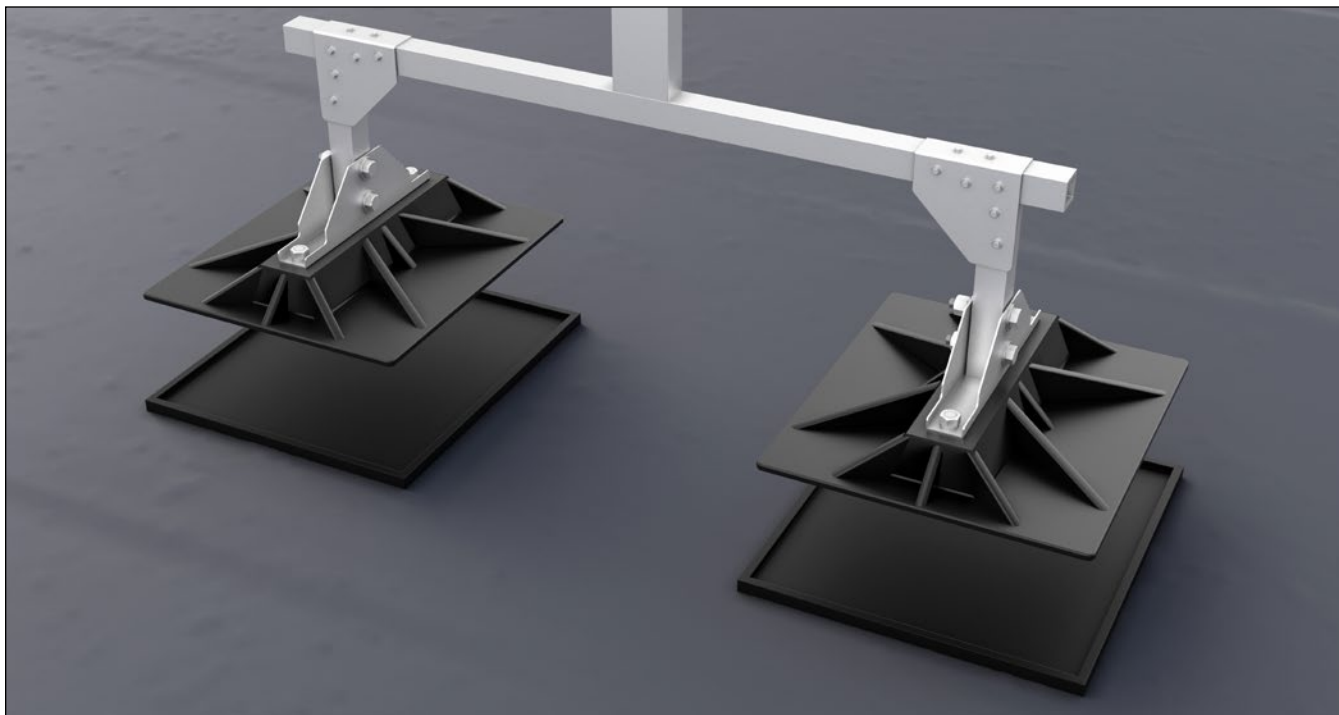
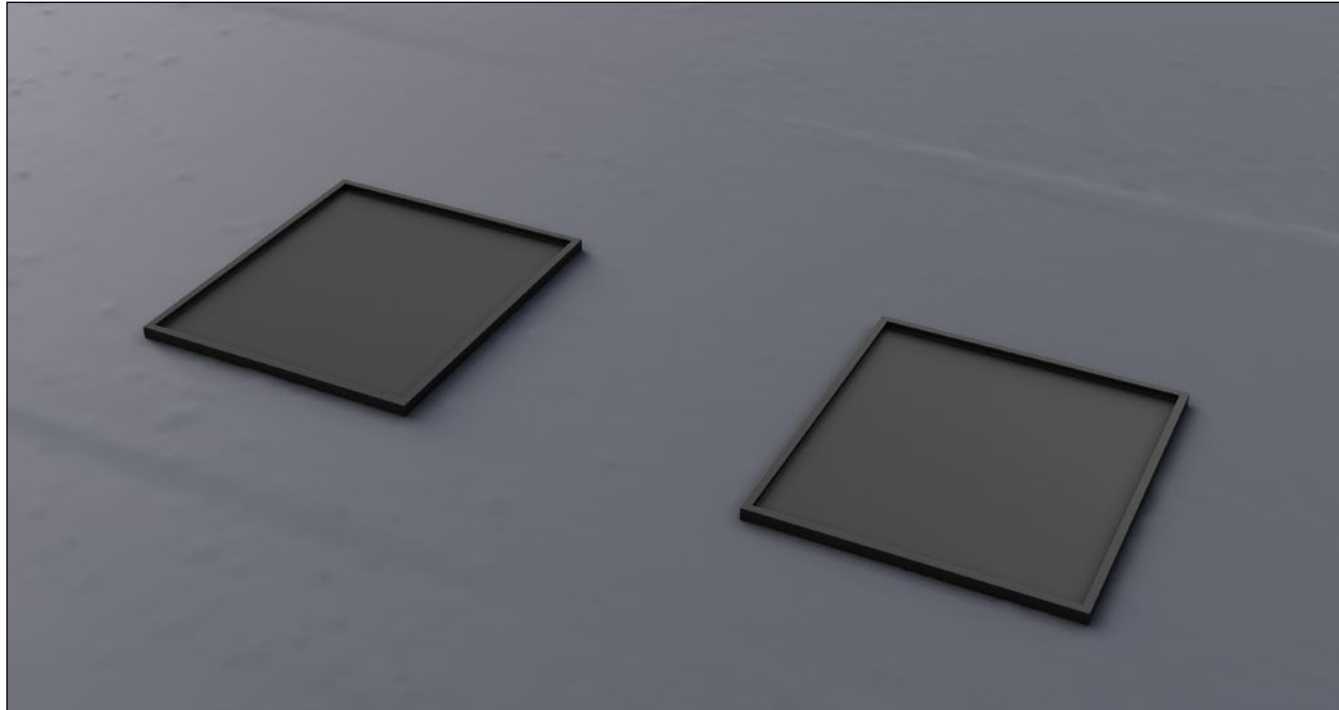

3. Using the **1" TEK SCREWS**, secure the **GUSSET PLATE** to one side of the **T-BAR**. Be sure to have the side with 2 holes on top of the **T-BAR**.

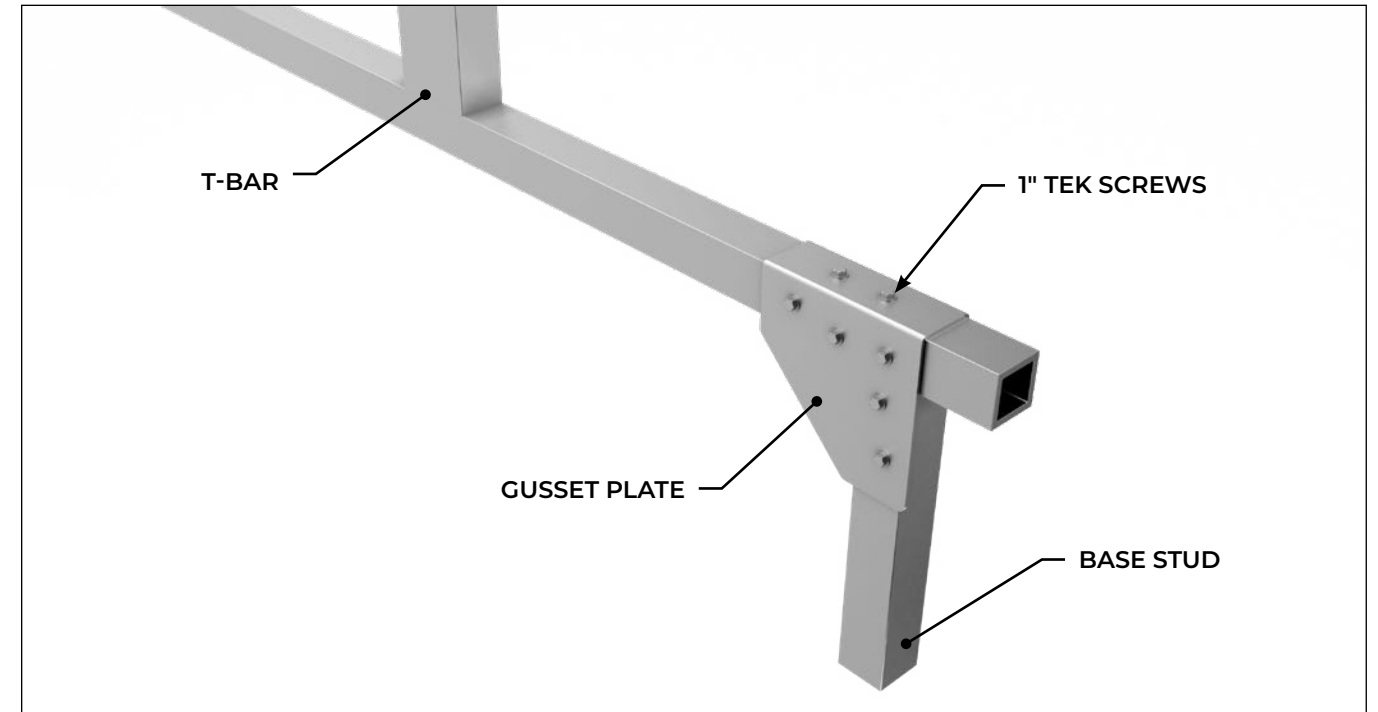

4. Align one **BASE STUD** to the bottom of the **T-BAR** and holes in the **GUSSET PLATE**. Secure with the **1" TEK SCREWS** through all 5 holes in the **GUSSET PLATE**.
5. Repeat steps 3 and 4 for the other **GUSSET PLATE** and **BASE STUD**.

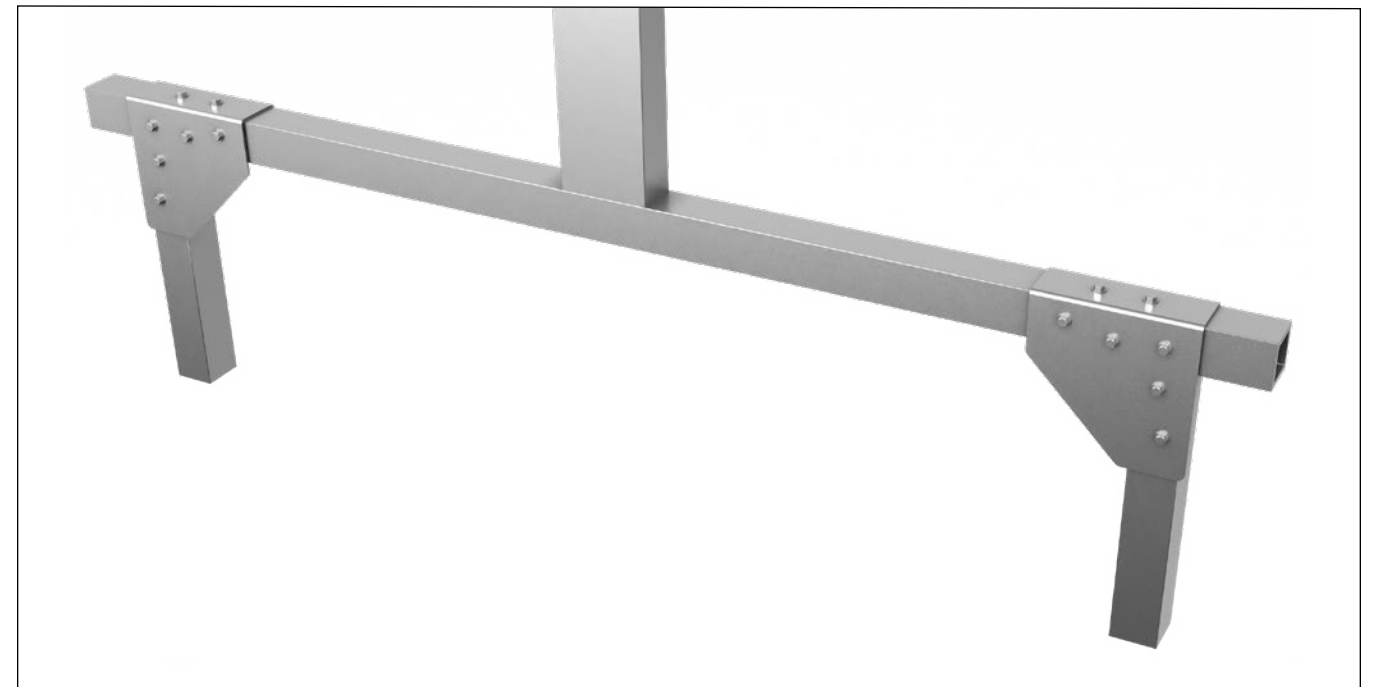

6. Insert the **BASE STUD** into the **FOOT** and secure together (top & bottom holes) with **2" HEX HEAD BOLT**, **(2) FLAT WASHERS**, **LOCK WASHER** and **HEX NUT**. Repeat on the other **FOOT**.

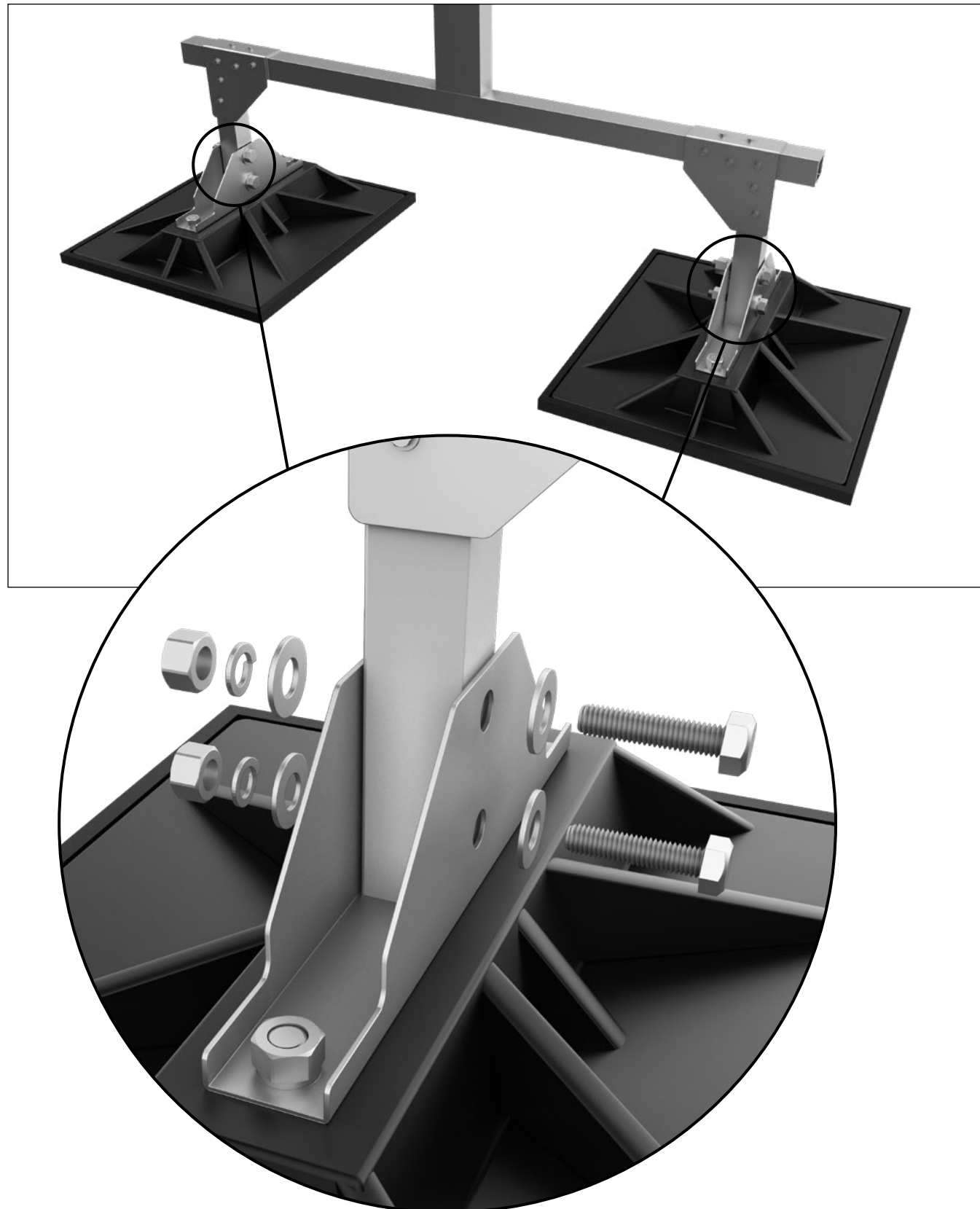

7. Drill $17/32$ " holes and attach the **ANGLE BRACKETS** to the **UPRIGHT SUPPORT TUBE** using the **4" HEX HEAD BOLT**, **(2) FLAT WASHERS**, **LOCK WASHER**, and **HEX NUT**. Confirm **ANGLE BRACKETS** orientation prior to tightening completely.

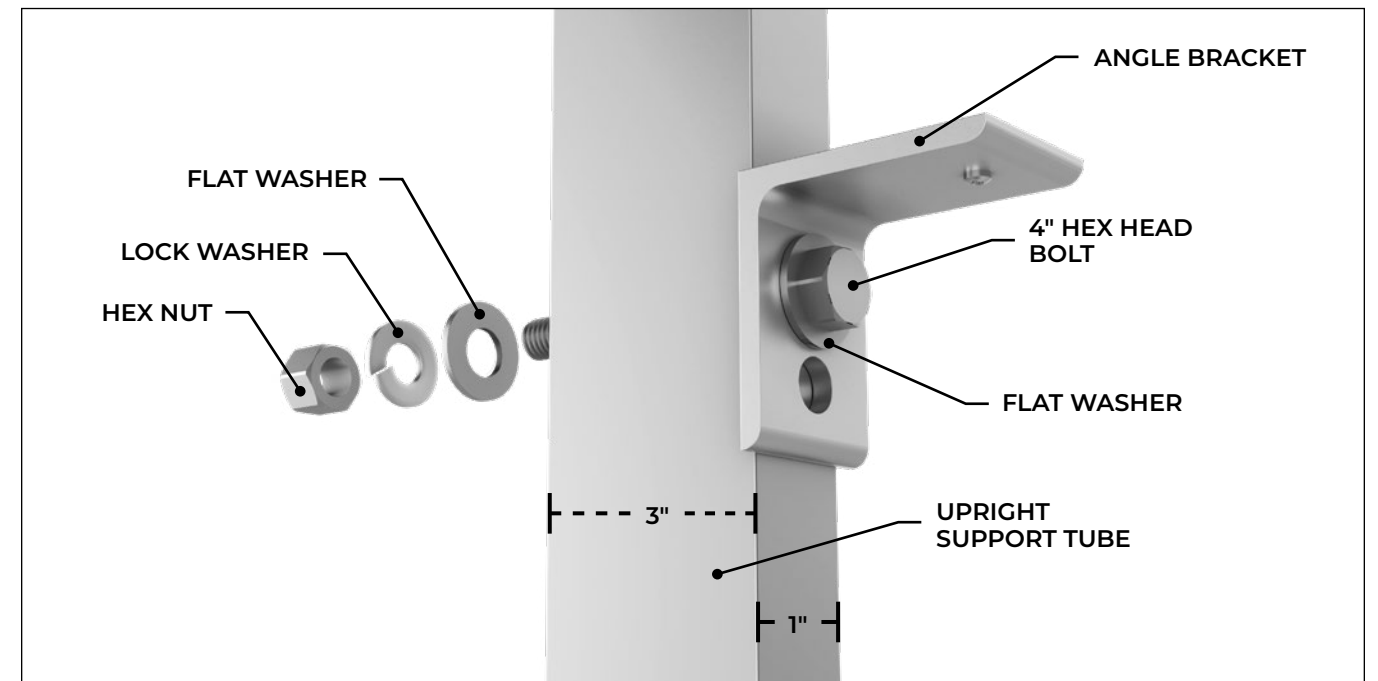

ATTACHING TO RAILS:

1. Mark and drill a $5/16$ " through hole in the **TOP** and **BOTTOM RAILS** where the holes in the **ANGLE BRACKETS** will be located.
2. Secure to the **TOP** and **BOTTOM RAILS** with a $3/4$ " **HEX HEAD BOLT**.
3. Repeat for any additional locations.



UNIT-ATTACHED INSTALL STEPS CONTINUED

16. Insert the **SLIDING PANELS** into retainer channels of the **BOTTOM RAIL** according to the panel layout in **Submittal Drawings**.

Note: SLIDING PANELS are to be staggered between the inner and outer retainer channels, with the corner panels always in the outer channel

The quantity and position of the SLIDING PANELS will vary across different screening applications. The overlap between the inner and outer panels will vary from approximately 2" to 6".

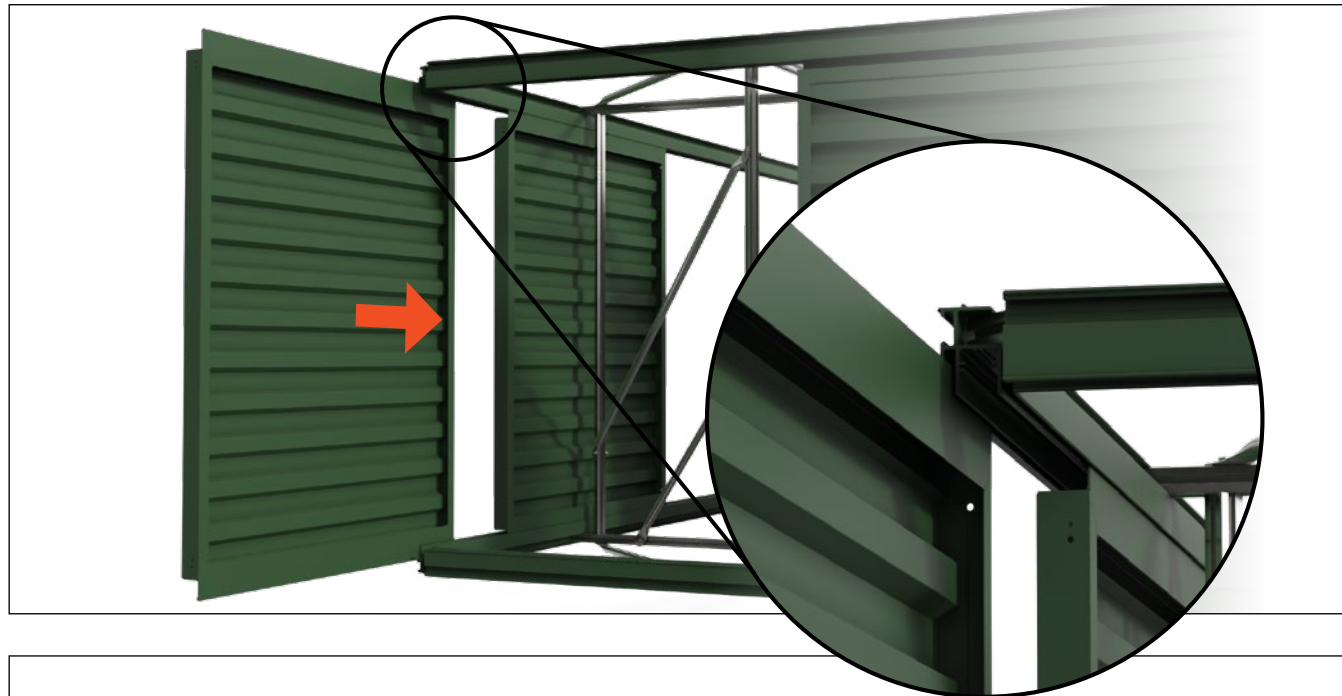

17. With all the **SLIDING PANELS** installed, begin at one corner with an **END CAP**, and position it flush over the ends of both the **TOP RAIL** and **BOTTOM RAIL**. Pre-drill pilot holes and use the **1 1/2" TEK SCREWS** to attach the **END CAP** to the **TOP** and **BOTTOM RAIL** extrusions at top and bottom.

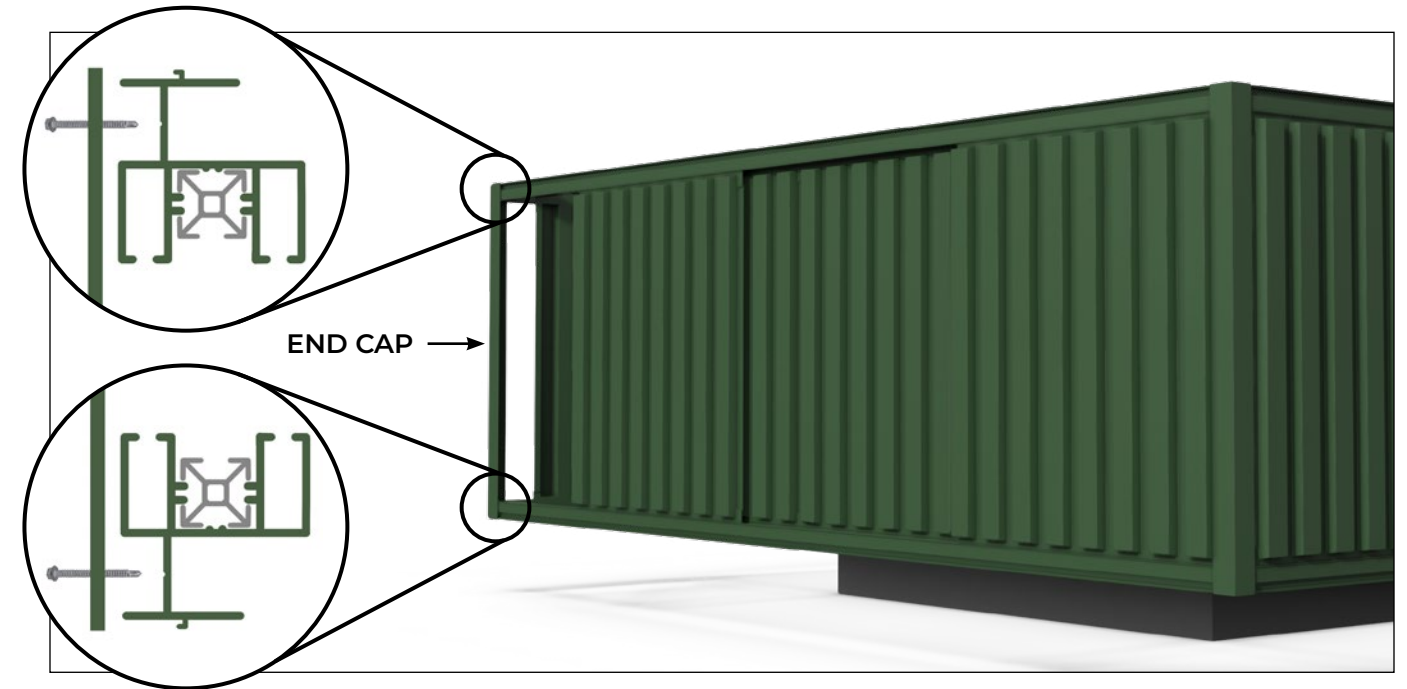

18. Apply the **DISCONNECT STICKER** on the outside surface of the **SLIDING PANEL** that has the RTU's Disconnect Switch located behind it. Remove the backing from the label and apply it to this panel so that it is plain view.



19. Walk around the entire RTU screen to inspect and make any adjustments in the position of the panels. Adjust and move **SLIDING PANELS** left or right for even spacing to complete your installation.



20. Use the provided **TOUCH UP PAINT** in the same color as your Envisor® screen to cover all exposed hardware, and fix any small panel scratches.

21. Select a corner of the **BOTTOM RAIL** to place the **NAME PLATE**.

- 21.1. Center and level the **NAME PLATE**, mark the holes from the plate onto the **BOTTOM RAIL**.
- 21.2. Drill 1/8" holes at the marks.
- 21.3. Place two **Drive Pin Rivets** into the drilled holes.
- 21.4. Hit heads of **Drive Pin Rivets** to secure into structure.



ANNUAL MAINTENANCE

INSPECTION:

- ABS Panels – Visually inspect ABS panels. Replace panels if any sign of cracking or excess surface degradation appears
- Metal Panels – Visually inspect metal panels.
- Aluminum Components – Visually inspect all components for loose or missing hardware.
- Please call Customer Service at 877-727-3367 concerning infill panel or aluminum component replacement information.

CLEANING:

- Clean panels with a mild detergent and water (a light washing is recommended)
- Clean debris from panel retainer tracks
- ⚠️ **WARNING** – The use of petroleum-based oils, solvents, or paints on panels may produce minute cracks and/or discoloration on panel surface.

PAINT TOUCH UP:

- Use manufacturer-supplied touch up paint as necessary.

REPLACEMENT PART ORDERING

ACRYLICAP® ABS SERIES PANEL SPECS:

- Acrylicap® uses .187 acrylic-capped ABS for UV protection
- All standard panels are 45" wide
- Standard panel heights are 35", 52", 70"
- Panels can be stacked for additional coverage
- Weight approximately 1.1lbs/sq ft

METAL SERIES PANEL SPECS:

- Frames are 6063 T6 extruded aluminum
- Frame infill material thickness varies depending on infill choice
- Sherwin Williams 4000 Series Powder-Coated Components
- Pricing varies by panel style

TO ORDER CALL 877-727-3367